



## ISUZU D-MAX BLADE RG MY2024-ON PREDATOR & TORO FRONT BAR

### **IMPORTANT! – READ BEFORE INSTALLATION**

- When installed in accordance with these instructions, the front protection bar does not affect the operation of the vehicle's SRS airbags.
- This product must be installed exactly as per these instructions using only hardware supplied.
- Take a few moments to read instructions thoroughly before beginning work.
- In the event of damage to any bar component please contact OFFROAD ANIMAL to arrange repair/replacement of components.
- Do not use this product for any vehicle make or model other than that specified on these instructions.
- Do not remove labels from this product.
- This product and its fixings must not be modified in any way unless stated in these fitting instructions.
- The installation of this product is recommended for trained personnel.
- These instructions are correct at time of publication. OFFROAD ANIMAL cannot be held responsible for the impact of any changes subsequently made by the vehicle manufacturer. If you find something has changed please contact us to let us know!
- During installation it is the duty of the installer to check correct operation/clearances of all components.
- If Instructions are to be printed for reference in the workshop, it is recommended that they are printed in colour, for best legibility.

## GENERAL CARE AND MAINTENANCE

Use caution when cleaning with pressure washers, as they may compromise the product coating's integrity. Exercise care to avoid surface damage.

Only wash the product with a PH neutral car wash to prevent paint damage and discolouration.

Do not use acidic or alkaline based cleaning products.

Plastic parts may be maintained with silicone spray.

It is important to perform regular checks (pre/during/post trip or on an annual basis) on the installed product. More frequent checks may be required in extreme use cases. Checks include:

- Visual inspection for damage (eg. cracks, chips, dents etc.)
- Electrical wiring is not rubbing anything or worn out
- Bolts are torqued to correct specification (see torque guide below)

For touching up small stone chips, Offroad Animal recommends the following paint products:

- Dupli-Color Trim & Bumper Paint Black (TB101)
- VHT Hood, Bumper & Trim Paint Black (SP27)

## BOLT TORQUE SETTINGS

Use the following bolt torques on all general fasteners, unless otherwise specified.

GENERAL FASTENERS	
Size	Torque Nm
M5	5 Nm
M6	9 Nm
M8	22 Nm
M10	44 Nm
M12	77 Nm

Use the following bolt torques on all structural front bar mount and tow point fasteners, and rear towbar fasteners, unless otherwise specified.



FRONT BAR MOUNTS AND TOW POINTS + REAR TOWBAR	
Size	Torque Nm
M10	57 Nm
M12	100 Nm
M14	164 Nm
M16	248 Nm

**Always use a torque wrench to set correct torque settings. Ensure torque wrench is set to Nm unit of measurement. Otherwise perform conversion to lb-ft.**

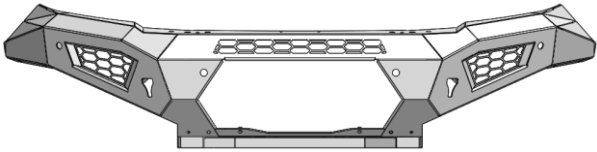
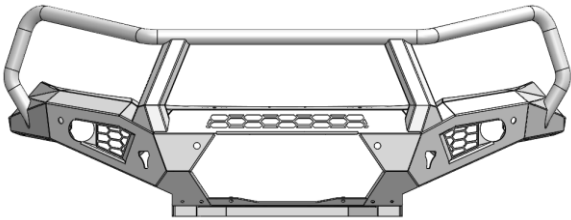
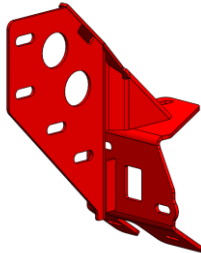
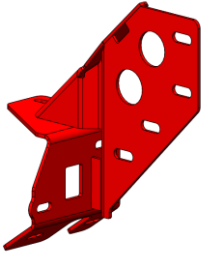

# PARTS LISTING

**IMPORTANT:** Check all parts are present before beginning work! Contact OFFROAD ANIMAL if something is missing.

## Main Parts – In the Box

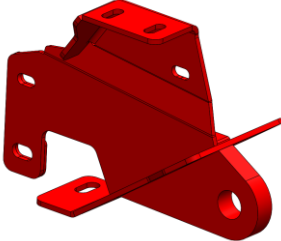
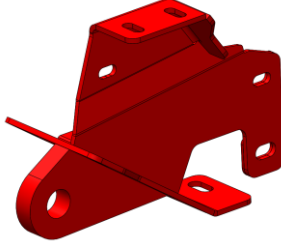
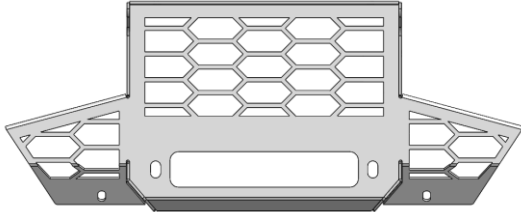
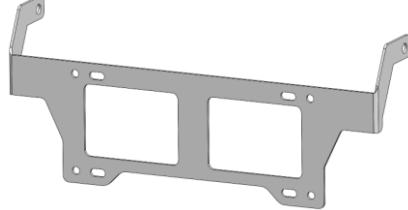
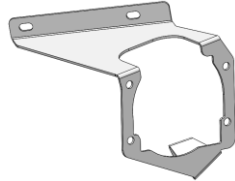
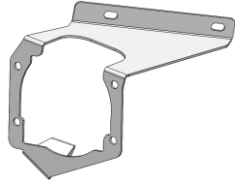
Qty	Part Number	Description	Image
1	FB-IDM-RG-24-PR-ASM1	D-MAX MY24 Facelift Predator Bar Welded Assy	
<b>OR</b>			
1	FB-IDM-RG-24-TOR-ASM1	D-MAX MY24 Facelift Toro Bar Welded Assy	
1	FB-IDM-RG-21-PR-ASM2R	ISUZU DMAX 21+ IMPACT ASSY RH	
1	FB-IDM-RG-21-PR-ASM2L	ISUZU DMAX 21+ IMPACT ASSY LH	
<b>OR</b>			
1	FB-MBT-TF-25-PR-ASM2R	BT-50 TF MY25 Facelift Impact Assembly RH	

1	FB-MBT-TF-25-PR-ASM2L	BT-50 TF MY25 Facelift Impact Assembly LH	
1	FB-IDM-RG-21-PR-ASM3R	ISUZU DMAX 21+ TOW POINT ASSY RH	
1	FB-IDM-RG-21-PR-ASM3L	ISUZU DMAX 21+ TOW POINT ASSY LH	
1	FB-IDM-RG-24-PR-ASM2	D-MAX MY24 Facelift Mesh Fairlead Welded Assembly	
1	B-0822	WL Predator Number Plate Bracket	
1	B-1286R	D-MAX MY24 Facelift Fog Light Bracket RH	
1	B-1286L	D-MAX MY24 Facelift Fog Light Bracket LH	

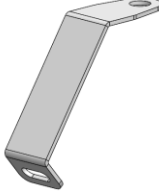
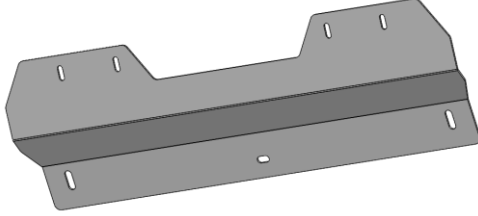
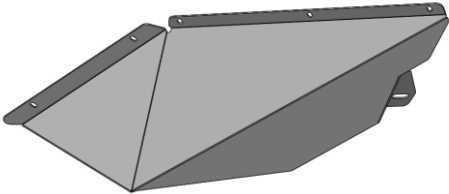
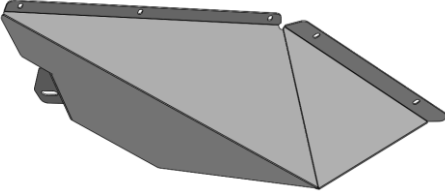
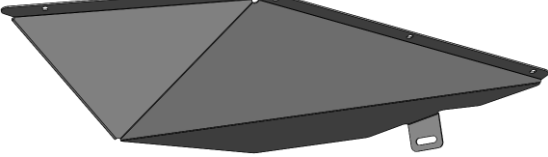
1	B-1287	D-MAX MY24 Facelift Pan Brace	
1	B-1293R	D-MAX RG Headlight Corner Infill Bracket RH	
1	B-1293L	D-MAX RG Headlight Corner Infill Bracket LH	
2	B-1296	D-MAX MY24 Facelift Grille Infill Brace	
1	U-0036	Isuzu DMAX 2021+ Predator Bash Plate	
1	U-0037R	Isuzu DMAX 2021+ Predator Side Underpanel RH	
1	U-0037L	Isuzu DMAX 2021+ Predator Side Underpanel LH	
<b>OR</b>			
1	U-0114R	MU-X MY25 Facelift Side Underpanel RH	

1	U-0114L	MU-X MY25 Facelift Side Underpanel LH	
1	U-0041	DMAX 21+ Supplementary Underpanel	
4	CPHP035	Plastic Hole Insert, 22MM, Black, Tigerlink Hardware CPHP035	
1	F-0031R	D-MAX MY24 Facelift Grille Infill RH	
1	F-0031L	D-MAX MY24 Facelift Grille Infill LH	
1	FB-IDM-RG-21-PR-ADRCP	ADR Compliance Plate DMAX 21+	
1	OFA-LOGO	Offroad Animal Metal Logo	
1	FI Note	Fitting Instruction Note	N/A
1	TK-FB-IDM-RG-24	Tape Kit - D-MAX 24+, 3M5952, 2x 30x6mm, 2x 50x6mm, 2x 75x15mm	N/A
2	PWS-SIDE-275	Pinch Weld PWS53S - Side Bulb Seal 275mm	N/A

<b>TORO ONLY</b>			
<b>2</b>	B-0649	Toro Antenna Bracket - 90 Degree Tall	
<b>1</b>	B-1292R	D-MAX MY24 Facelift Toro Indicator Bracket RH	
<b>1</b>	B-1292L	D-MAX MY24 Facelift Toro Indicator Bracket LH	
<b>2</b>	LED Autolamps 80AW	LED AUTOLAMPS 80AW LED INDICATOR PARKER COMBO LIGHT, SINGLE BLISTER PACK	
<b>1</b>	HPH-IDM-RG- 24	Offroad Animal High beam piggy back adapter to suit Isuzu DMAX MY2024+	N/A
<b>1</b>	CAT6-IDMB-Q	Dmax (24+) - Indicator and Highbeam Piggyback (PAIR)	N/A



## PREDATOR Fasteners – Contained in Small Parts Kit Bag

Qty	Part Number	Description
35	M6x16 BHCS BLACK ZINC	SCREW, BUTTON HEAD CAP, M6X16X1 GR12.9, ISO4042 ZnNi BLACK PASSIVATED FINISH
35	M6 FLAT WASHER BLACK ZINC	M6 Flat Washer, 12x6.1x1, ISO4042 ZnNi BLACK PASSIVATED FINISH
16	M6 FLANGE NUT	Flange Nut, M6x1 G8.8 ZP
10	M6CN3MM	CAGE NUT M6x2.6-3.5
2	M8 X 20 HEX	Bolt Hex, M8X20x1.25, GR8.8 ZP
2	M8 X 16 BHCS BZP	SCREW, BUTTON HEAD CAP, M8X16X1.25 GR12.9, ISO4042 ZnNi BLACK PASSIVATED FINISH
4	M8 X 20 BHCS BLACK ZINC	SCREW, BUTTON HEAD CAP, M8X20X1.25, ISO4042 ZnNi BLACK PASSIVATED FINISH
4	M8 X 30 BHCS BLACK ZINC	SCREW, BUTTON HEAD CAP, M8X30X1.25, ISO4042 ZnNi BLACK PASSIVATED FINISH
4	M8 HD FLAT WASHER	M8 FLAT WASHER - High Tensile 19x8x1.9mm
10	M8 HD FLAT WASHER - BZP	M8 FLAT WASHER - High Tensile 19x8x2mm, ISO4042 ZnNi BLACK PASSIVATED FINISH
2	M8 NYW	Washer, M8, Nylon
2	M8 NYLOC	NYLOC SELF LOCKING NUT, ST STL A2 ISO
13	M10 x 30	Bolt Hex, M10X30x[1.5], GR8.8 ZP
13	M10 FW LHD	WASHER, FLAT M10X28.5X2.5
9	M10 FLANGE NUT	Flange Nut, M10x1.5 G8.8 ZP
12	M12X30	Bolt Hex, M12X30x1.75, GR8.8 ZP
14	M12 FW LHD	M12 FW Large Heavy Duty
8	M12 FLANGE NUT	Flange Nut, M12x1.75 G8.8 ZP
2	M12 Nyloc nut	M12 NYLOC NUT
2	FB-IDM-RG-21-PR-ASM4	DMAX 21+ Tow Point Nut Plate
2	NP-COM-M10-190-ASM0	M10 LOLLYPOP NUT PLATE 190MM LONG

**TORO Fasteners – Contained in Small Parts Kit Bag**

Qty	Part Number	Description
41	M6x16 BHCS BLACK ZINC	SCREW, BUTTON HEAD CAP, M6X16X1 GR12.9, ISO4042 ZnNi BLACK PASSIVATED FINISH
41	M6 FLAT WASHER BLACK ZINC	M6 Flat Washer, 12x6.1x1, ISO4042 ZnNi BLACK PASSIVATED FINISH
22	M6 FLANGE NUT	Flange Nut, M6x1 G8.8 ZP
10	M6CN3MM	CAGE NUT M6x2.6-3.5
2	M8 X 20 HEX	Bolt Hex, M8X20x1.25, GR8.8 ZP
2	M8 X 16 BHCS BZP	SCREW, BUTTON HEAD CAP, M8X16X1.25 GR12.9, ISO4042 ZnNi BLACK PASSIVATED FINISH
8	M8 X 20 BHCS BLACK ZINC	SCREW, BUTTON HEAD CAP, M8X20X1.25, ISO4042 ZnNi BLACK PASSIVATED FINISH
4	M8 X 30 BHCS BLACK ZINC	SCREW, BUTTON HEAD CAP, M8X30X1.25, ISO4042 ZnNi BLACK PASSIVATED FINISH
4	M8 HD FLAT WASHER	M8 FLAT WASHER - High Tensile 19x8x1.9mm
4	M8 FLAT WASHER- BLACK ZINC	M8 FLAT WASHER, 16.5x8.4x1.2, ISO4042 ZnNi BLACK PASSIVATED FINISH
10	M8 HD FLAT WASHER - BZP	M8 FLAT WASHER - High Tensile 19x8x2mm, ISO4042 ZnNi BLACK PASSIVATED FINISH
2	M8 NYW	Washer, M8, Nylon
2	M8 NYLOC	NYLOC SELF LOCKING NUT, ST STL A2 ISO
13	M10 x 30	Bolt Hex, M10X30x[1.5], GR8.8 ZP
13	M10 FW LHD	WASHER, FLAT M10X28.5X2.5
9	M10 FLANGE NUT	Flange Nut, M10x1.5 G8.8 ZP
12	M12X30	Bolt Hex, M12X30x1.75, GR8.8 ZP
14	M12 FW LHD	M12 FW Large Heavy Duty
8	M12 FLANGE NUT	Flange Nut, M12x1.75 G8.8 ZP
2	M12 Nyloc nut	M12 NYLOC NUT
2	FB-IDM-RG-21-PR-ASM4	DMAX 21+ Tow Point Nut Plate
2	NP-COM-M10-190-ASM0	M10 LOLLYPOP NUT PLATE 190MM LONG

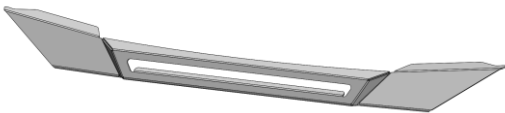
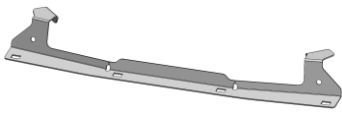
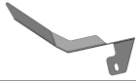
**Blade Supplementary Parts Kit – In the Box**

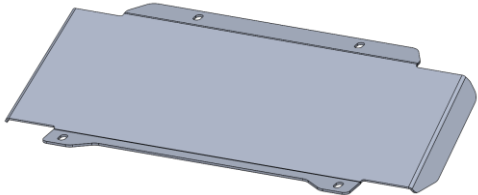
Qty	Part Number	Description	Image
1	B-1574	D-MAX Blade Grille Infill	
1	B-1575	D-MAX Blade Grill Infill Mount	
1	B-1576R	D-MAX Blade Flare Endcap RH	
1	B-1576L	D-MAX Blade Flare Endcap LH	
1	U-0113	D-MAX Blade Lower Bash Plate	
1	TK-FB-IDM-RG-24	Tape Kit - D-MAX 24+, 3M5952, 2x 30x6mm, 2x 50x6mm, 2x 75x15mm	N/A

**Blade Fasteners – Contained in Small Parts Kit Bag**

Qty	Part Number	Description
2	M6 X 12 HEX	M6X12 HEX BOLT, ZP, 8.8
4	M6x16 BHCS BLACK ZINC	SCREW, BUTTON HEAD CAP, M6X16X1 GR12.9, ISO4042 ZnNi BLACK PASSIVATED FINISH
2	M6 PANEL WASHER	M6 PANEL WASHER - Stainless A2-70 G304 M6x18x1.6mm
4	M6 FLAT WASHER BLACK ZINC	M6 Flat Washer, 12x6.1x1, ISO4042 ZnNi BLACK PASSIVATED FINISH
2	M6 FLANGE NUT	Flange Nut, M6x1 G8.8 ZP
4	M6CN2MM	CAGE NUT M6x1.6-2.5
2	M8 X 20 BHCS BLACK ZINC	SCREW, BUTTON HEAD CAP, M8X20X1.25, ISO4042 ZnNi BLACK PASSIVATED FINISH
2	M8 FLAT WASHER- BLACK ZINC	M8 FLAT WASHER, 16.5x8.4x1.2, ISO4042 ZnNi BLACK PASSIVATED FINISH
2	M10X50X1.25	Bolt Hex, M10X50X1.25, GR8.8 ZP
2	M10 FW LHD	WASHER, FLAT M10X28.5X2.5
2	P-0306	LC300 Inner Mount Spacer Block
2	P-0394	8MM Circular Spacer Suit M12 Bolt
2	NP-COM-M8-100-ASM0	M8 Nut Plate 100mm

## TOOLS REQUIRED

The following tools will be required to install the product.

<b>Hand Tools</b>	<b>Power Tools</b>	<b>Workshop Equipment</b>
Metric Socket Set 10-19mm	Electric/Air Impact Driver (Optional)	Panel stand or Soft Blanket
Socket Extension Bar	Soldering Iron	Lifting Trolley
Metric Spanner Set 10-19mm	Air hacksaw or Jigsaw	Isopropyl Alcohol
Hex (Allen) Key Set 4-6mm	or Multi-tool	Rag
Trim Removal Tool	or Angle grinder	Cable Ties
Plastic Auto Trim Tool Set		Marker pen
Flat Blade Screwdriver Set		Ruler
Phillips Head Screwdriver Set		Measuring tape
Utility Knife		Masking tape
Side Cutters		Electrical tape
Pliers		Heat shrink
Wire Strippers		

# WORKSHOP SAFETY

It is the responsibility of the installer to always complete works in a safe manner. Make sure the following safety equipment is available and precautions are observed whilst fitting this product.

<p>Hearing Protection</p> 	<p>Always wear ear protection when using power tools.</p>
<p>Eye Protection</p> 	<p>Ensure eye protection is always worn when cutting or drilling.</p>
<p>Manual Handling</p> 	<p>Do not attempt to lift bar assemblies or rock sliders on your own.</p> <p>Always use two people to lift or use mechanical lifting aid such as hydraulic lifting trolley.</p>
<p>Vehicle Support</p> 	<p>Always ensure vehicle is properly supported when working on it. Do not attempt to fit products whilst suspension work is being carried out. Do not work under a vehicle supported only by a jack.</p>



1. Remove number plate from bumper and set aside.

**TOOLS REQUIRED**

Phillips head screwdriver

**FASTENERS**



2. Remove the 2x rear bash plate bolts with a 6mm Allen key.
3. Remove the 3x front bash plate bolts with a 5mm Allen key.
4. Fully remove and discard the bash plate.

**TOOLS REQUIRED**

5mm hex/Allen key  
6mm hex/Allen key

**FASTENERS**



5. Remove the bash plate front mount bracket by removing 2x 16mm hex bolts.
6. Retain these bolts.

**TOOLS REQUIRED**

16mm socket/spanner

**FASTENERS**

2x factory 16mm hex bolts

Retain for re-fitment



<p>7. Open the Bonnet.</p> <p>8. Remove 2x plastic push clips holding the factory air intake scoop. To remove each push clip, lever the centre section upwards using a flat blade screwdriver or trim tool, as shown. Retain these clips.</p>	<p><b>TOOLS REQUIRED</b></p> <p>Flat blade screwdriver or Trim tool</p>
<p>9. Remove the factory air intake scoop and set aside. Take care not to drop anything into the intake.</p>	<p><b>FASTENERS</b></p> <p>2x plastic push clips</p>

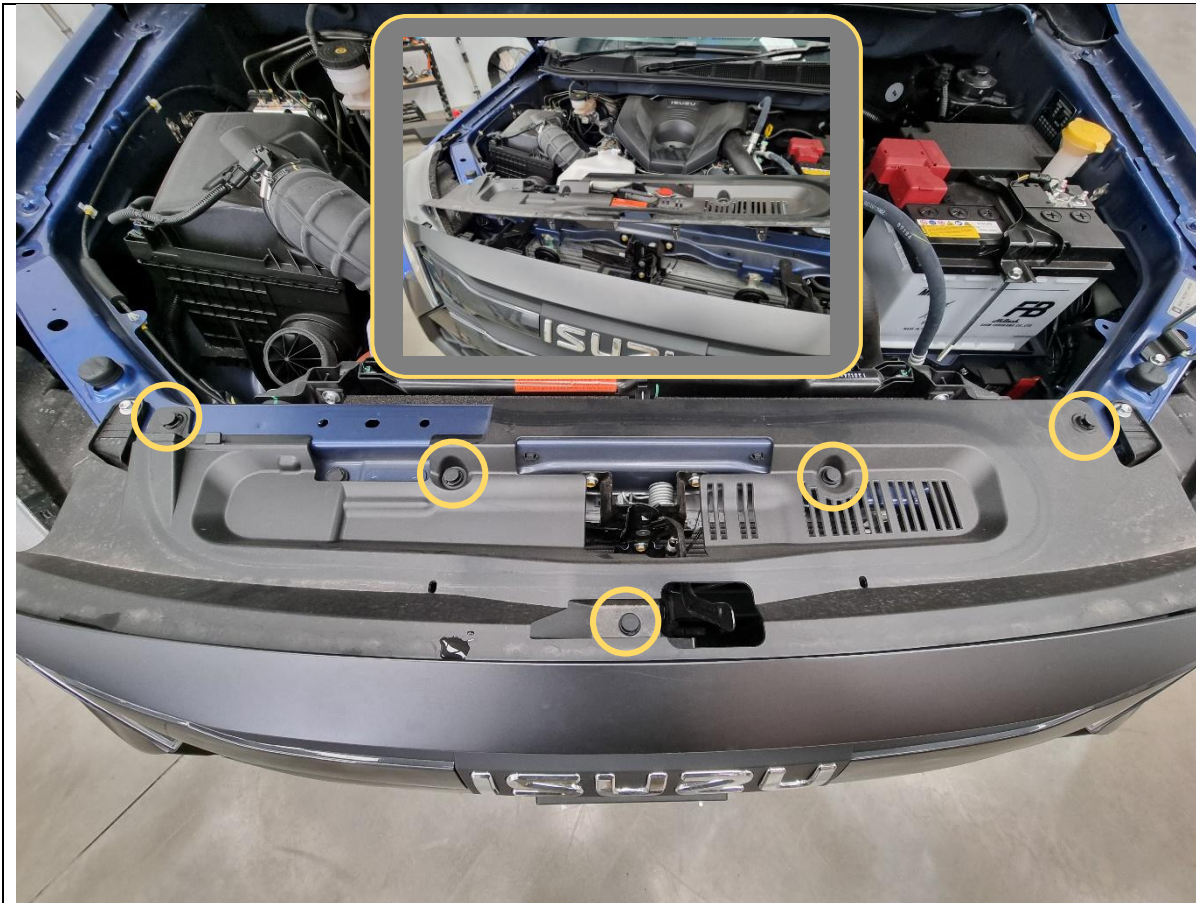

10. Remove 5x plastic push clips holding the radiator grille cover. Retain these clips.

11. Pull upwards to remove the radiator grille cover and set aside.

**TOOLS REQUIRED**

Flat blade screwdriver  
or  
Trim tool

**FASTENERS**

5x plastic push clips



12. Remove 6x plastic push clips holding the grille.  
There are 2x clips on the top edge, and 4x clips on the cross member on the inside of the grille.

**TOOLS REQUIRED**

Flat blade screwdriver  
or  
Trim tool

**FASTENERS**

6x plastic push clips



- 13. On the underside of the bumper, remove 2x plastic push clips holding the bumper to the inner support brackets. These are located near where the factory tie down hook/s are on each side of the chassis.
- 14. Retain these clips.

**TOOLS REQUIRED**

Flat blade screwdriver  
or  
Trim tool

**FASTENERS**

2x plastic push clips  
  
Retain for re-fitment

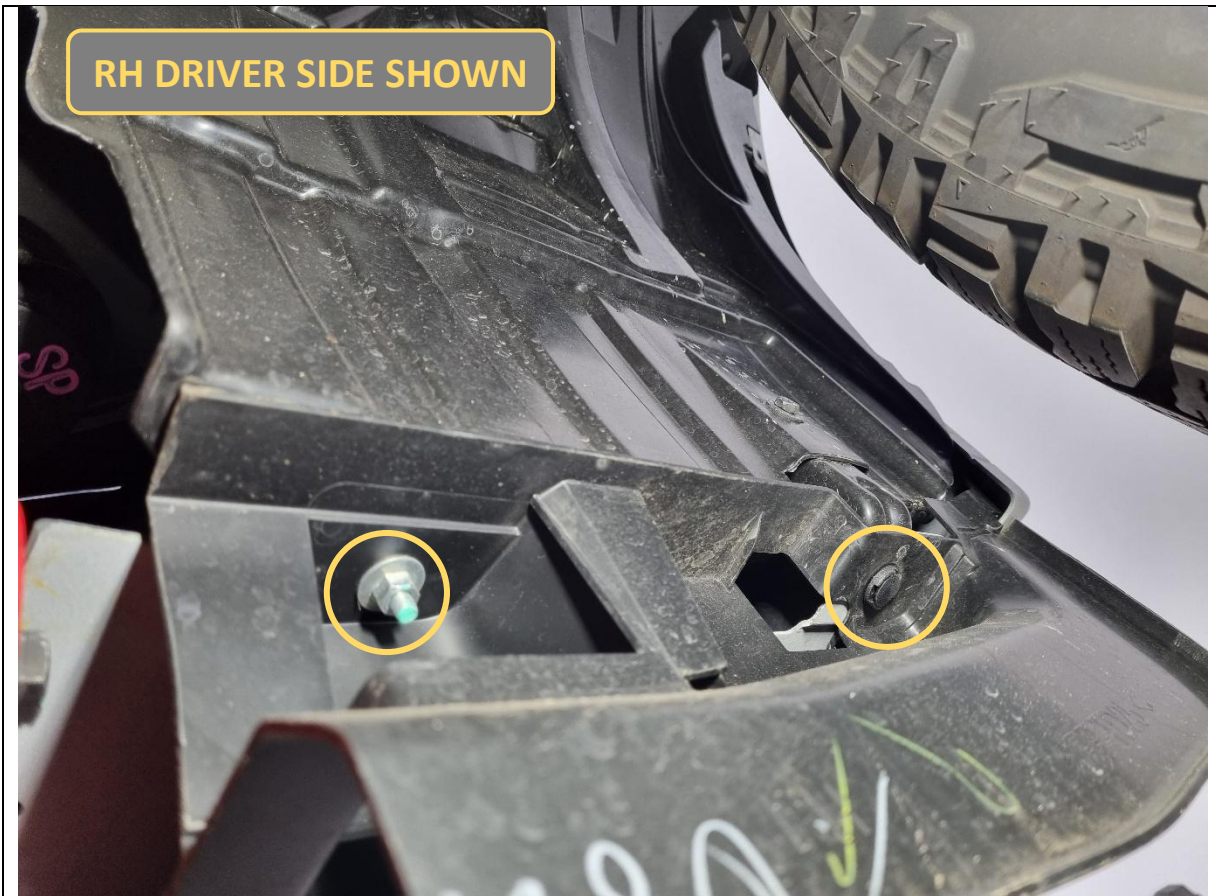

15. In the front wheel well area, remove 1x 10mm flange nut and 1x plastic push clip holding the bottom of the bumper to the wheel arch liner and outer support bracket. Do this for both sides.

**TOOLS REQUIRED**

Flat blade screwdriver  
or  
Trim tool

10mm socket

**FASTENERS**

2x plastic push clips  
2x factory 10mm flange nuts



16. In the front wheel well area, remove 2x 8mm hex screws holding the flare to the bumper. Do this for both sides.

**TOOLS REQUIRED**

8mm socket/spanner

**FASTENERS**

4x factory 8mm hex screws

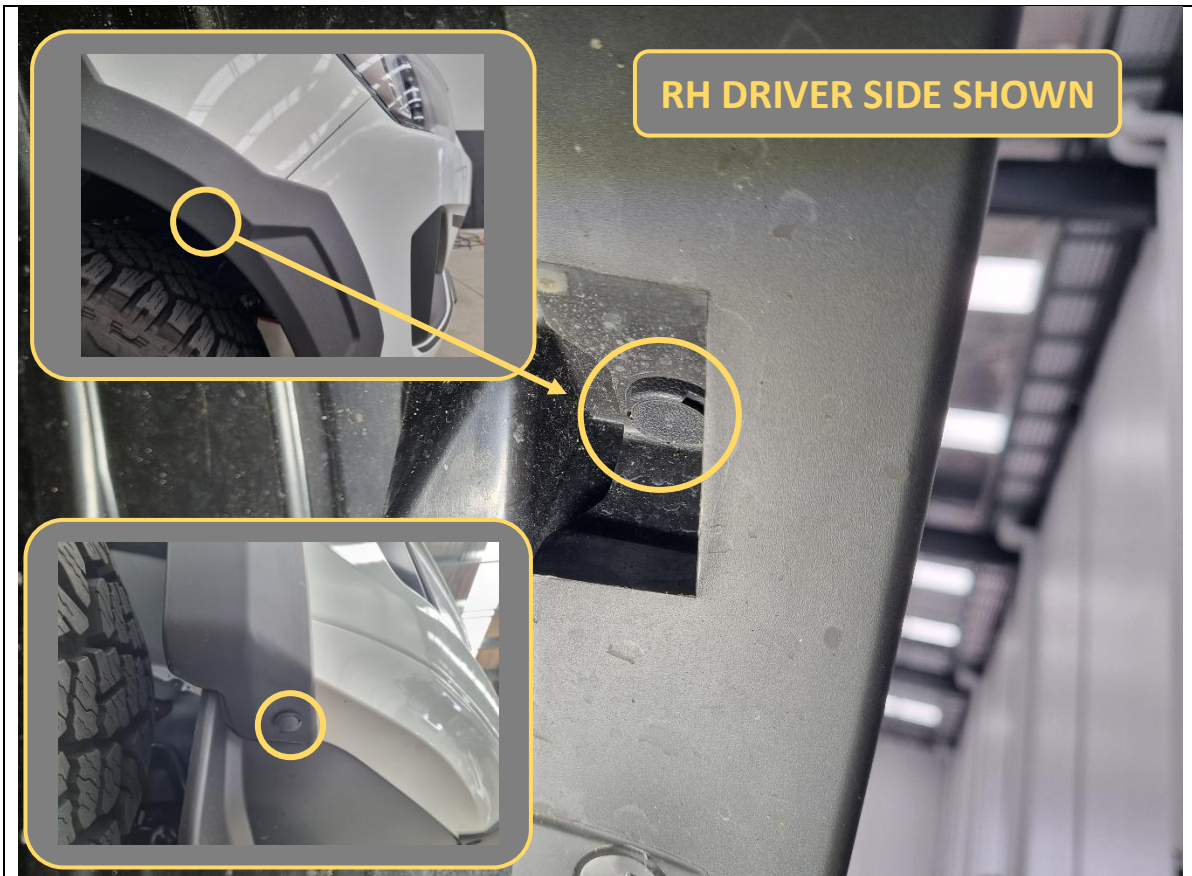

17. In the front wheel well area, remove 1x plastic push clip holding the flare to the where the front corner of the quarter panel would be. Retain this clip.
18. Remove the 1x plastic push clip holding the front bottom end of the flare to the bumper.
19. Do this for both sides.

**TOOLS REQUIRED**

Flat blade screwdriver  
or  
Trim tool

**FASTENERS**

4x plastic push clips

Retain for re-fitment



20. Starting from the bottom, pull on the front of the flare and separate it from the bumper.

Only the front section of the flare up to the quarter panel needs to be separated to allow the bumper to be removed.

If more of the flare is removed, then the double sided foam tape holding the flare to the quarter panel will need to be replaced.

**TOOLS REQUIRED**

**FASTENERS**



<p>21. Unclip the LH corner of the bumper by pulling away and outwards from the outer corner, starting from the outside and working in.</p>	<p><b>TOOLS REQUIRED</b></p>
<p>22. When bumper is loose, reach in and disconnect the 1x bumper harness connector located under the left-hand headlight.</p> <p>23. Unclip the RH corner, then fully remove the bumper from car and set aside.</p>	<p><b>FASTENERS</b></p>

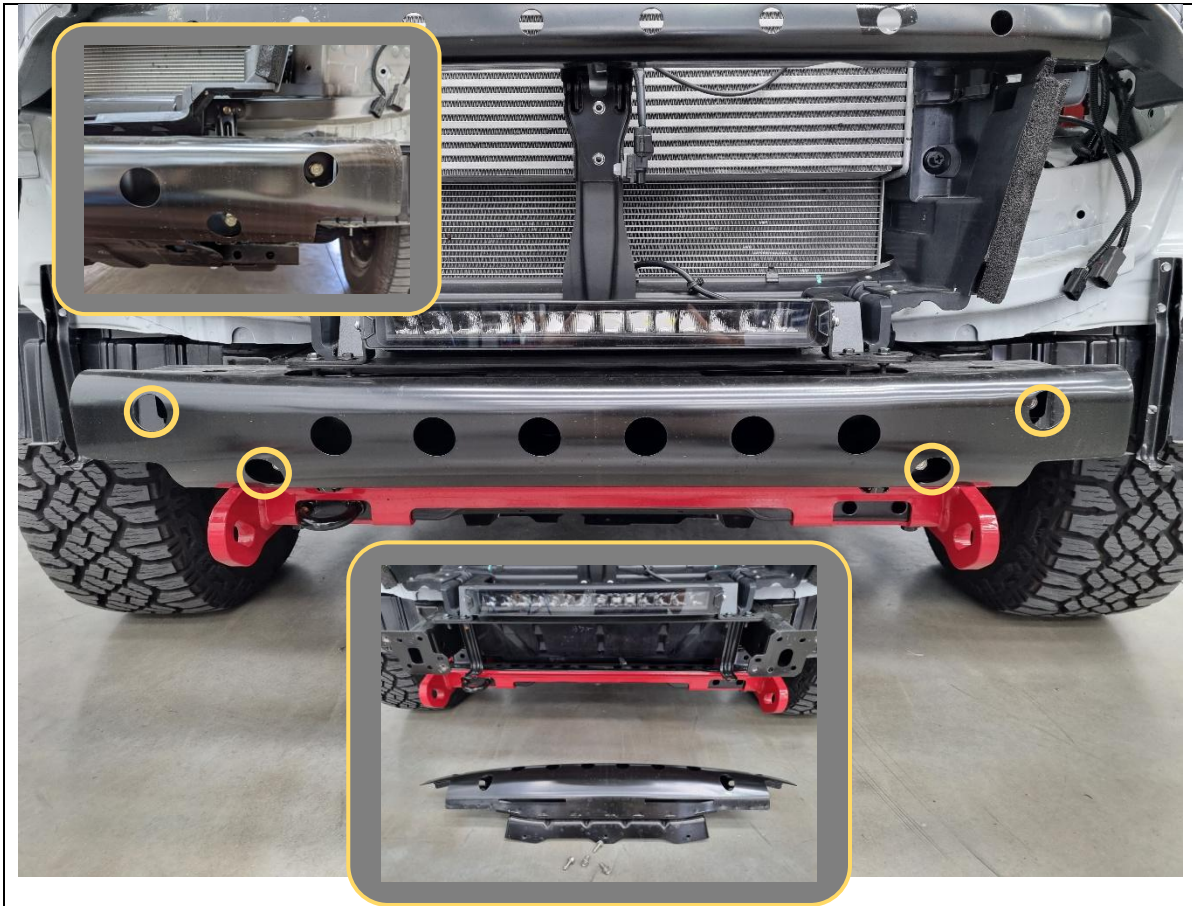

<p>24. Remove the 4x 14mm hex bolts securing the impact beam to the chassis.</p> <p>25. Remove and discard the impact beam. Retain bolts for fitting of mounts.</p>	<p><b>TOOLS REQUIRED</b></p> <p>14mm socket</p>
	<p><b>FASTENERS</b></p> <p>4x factory 14mm hex bolts</p> <p>Retain for re-fitment</p>

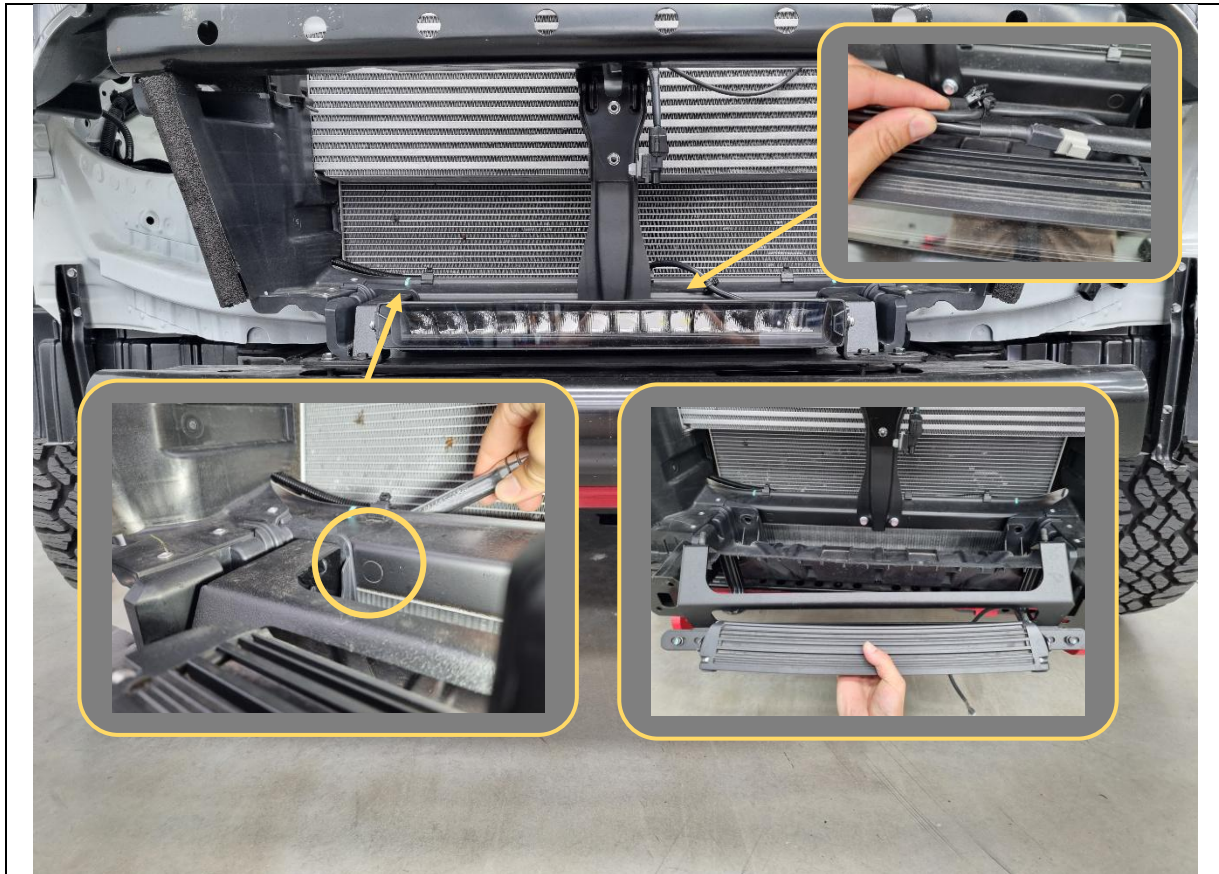

26. Cut the cable ties and unplug the light bar from the body harness.

27. Then remove the 2x 13mm hex nuts holding the light bar mounting bracket to the vehicle body.

The nuts are located behind the body frame member and can be accessed with a socket wrench or offset ring spanner.

28. Fully remove the light bar and its mounting bracket. The light bar shape is unsuitable for re-use in the Offroad Animal bull bar.

**TOOLS REQUIRED**

Side cutters

13mm socket/spanner

**FASTENERS**

2x 13mm factory hex nuts

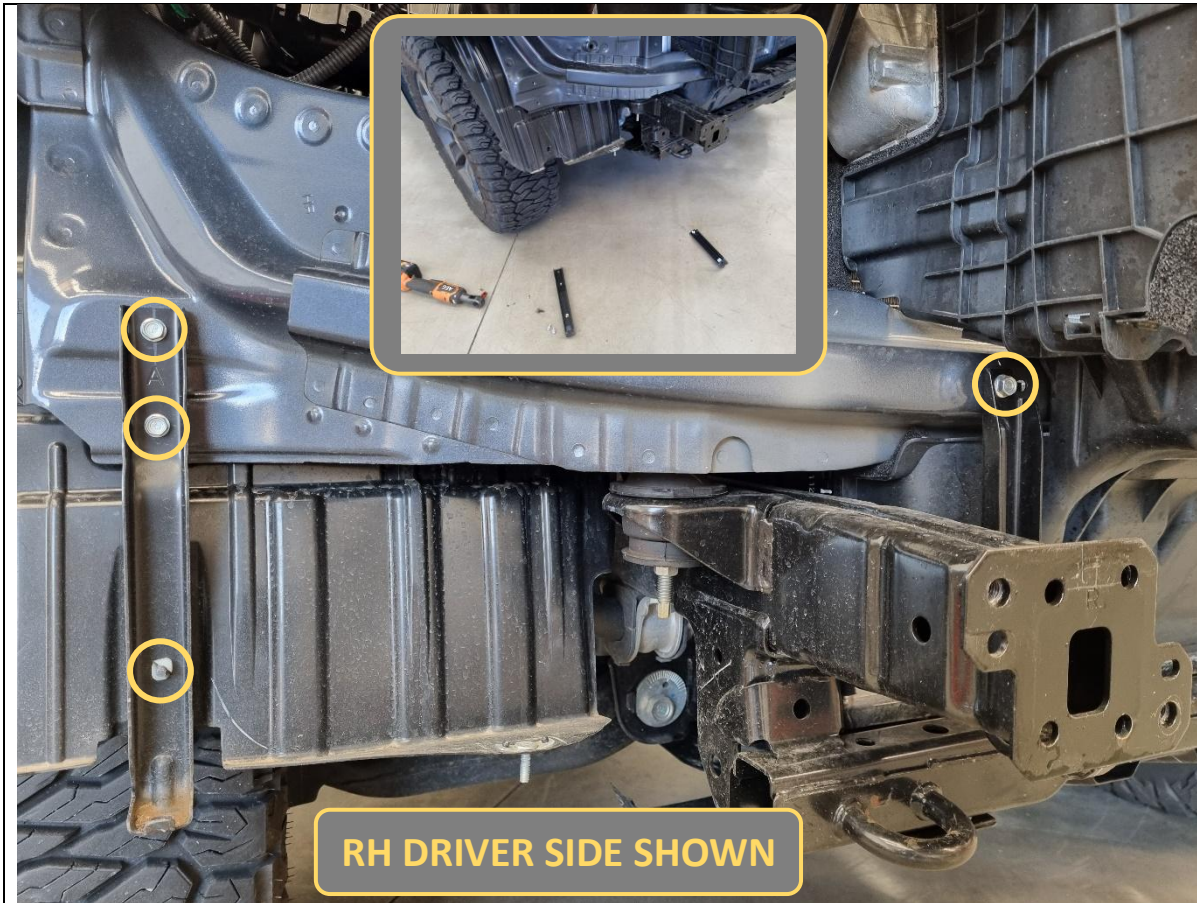

**RH DRIVER SIDE SHOWN**

- 29. Remove the 3x 10mm hex bolts securing each outer bumper support bracket.
- 30. Remove the 1x 10mm hex bolt securing each inner bumper support bracket.
- 31. Remove and discard the bumper supports.

**TOOLS REQUIRED**

10mm socket/spanner

**FASTENERS**

8x 10mm factory hex bolts

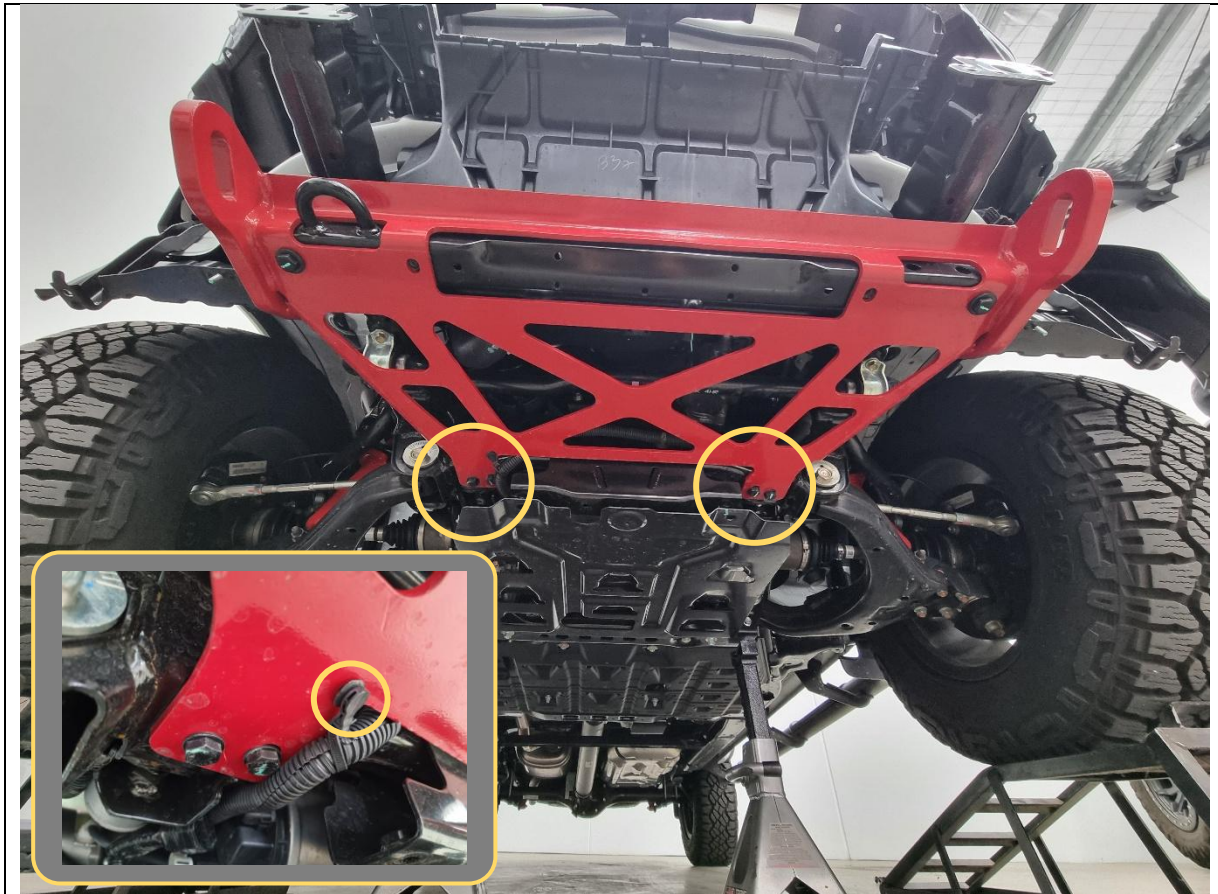

32. Remove the 4x 16mm hex bolts (2x per side) holding the rear of the tow point assembly.

33. Also unclip the harness from the tow point (see inset photo).

**TOOLS REQUIRED**

16mm socket/spanner

**FASTENERS**

4x factory 16mm hex bolts

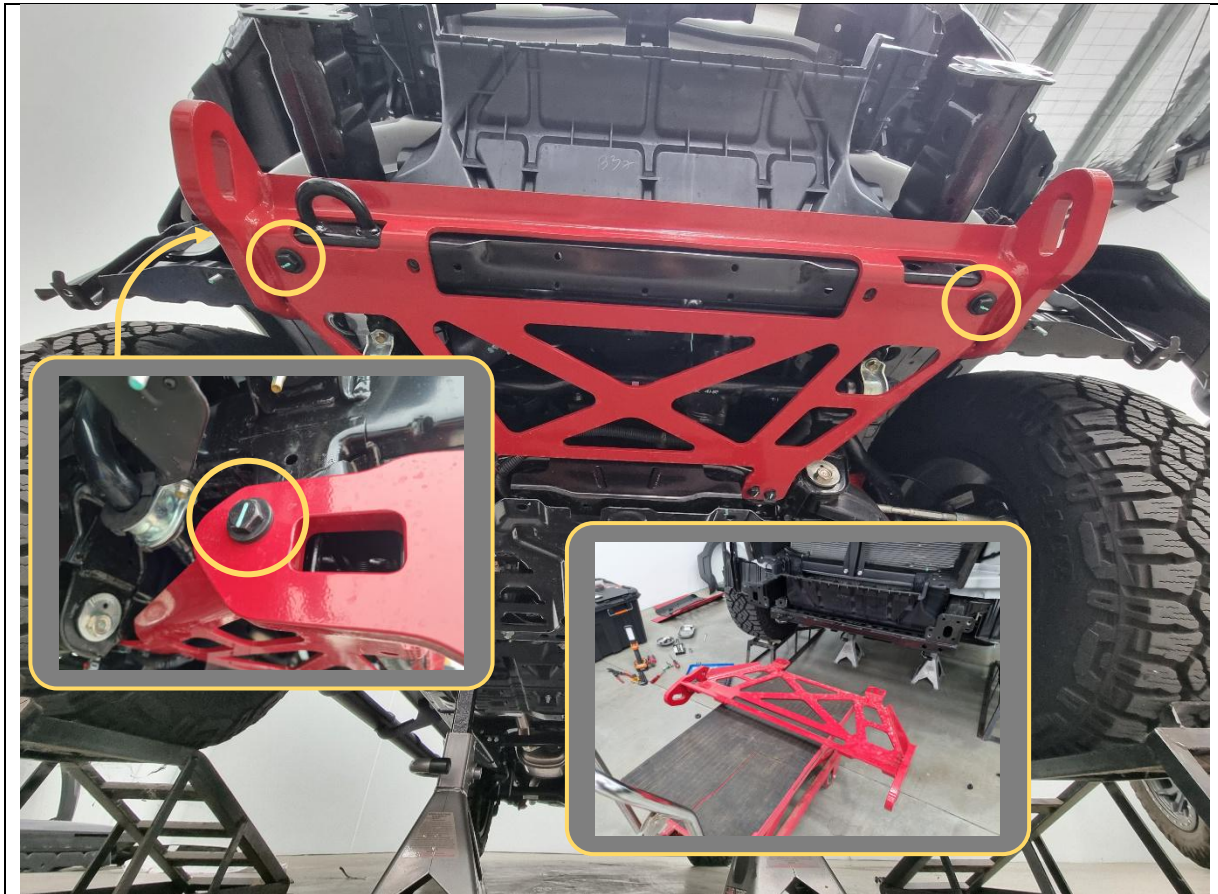

- 34. Before removing all the tow point bolts, support the tow point assembly with a lifting trolley or similar as it is quite heavy.
- 35. Remove 4x 18mm hex bolts holding the front of the tow point assembly (2x on underside, 1x on each side).
- 36. Fully remove the tow point assembly from the vehicle.

**TOOLS REQUIRED**

Lifting trolley

18mm socket/spanner

**FASTENERS**

4x factory 18mm hex bolts



37. Remove any leftover nutplates, flange nuts and/or spacers from the chassis where the tow point assembly was bolted to.

**TOOLS REQUIRED**

**FASTENERS**

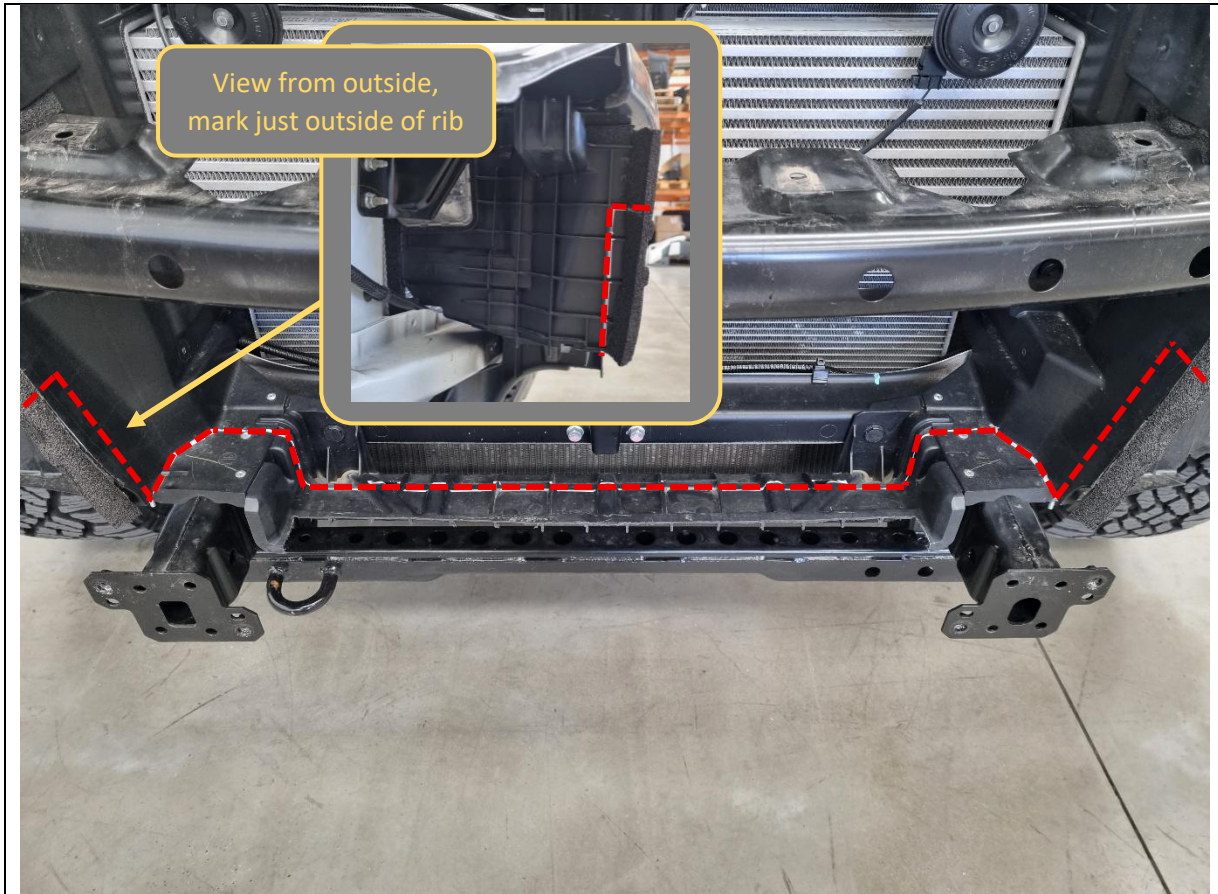

38. The plastic air guide needs to be trimmed. Use a marker pen and mark the air guide using the above images as reference.

**TOOLS REQUIRED**

Marker pen

**FASTENERS**

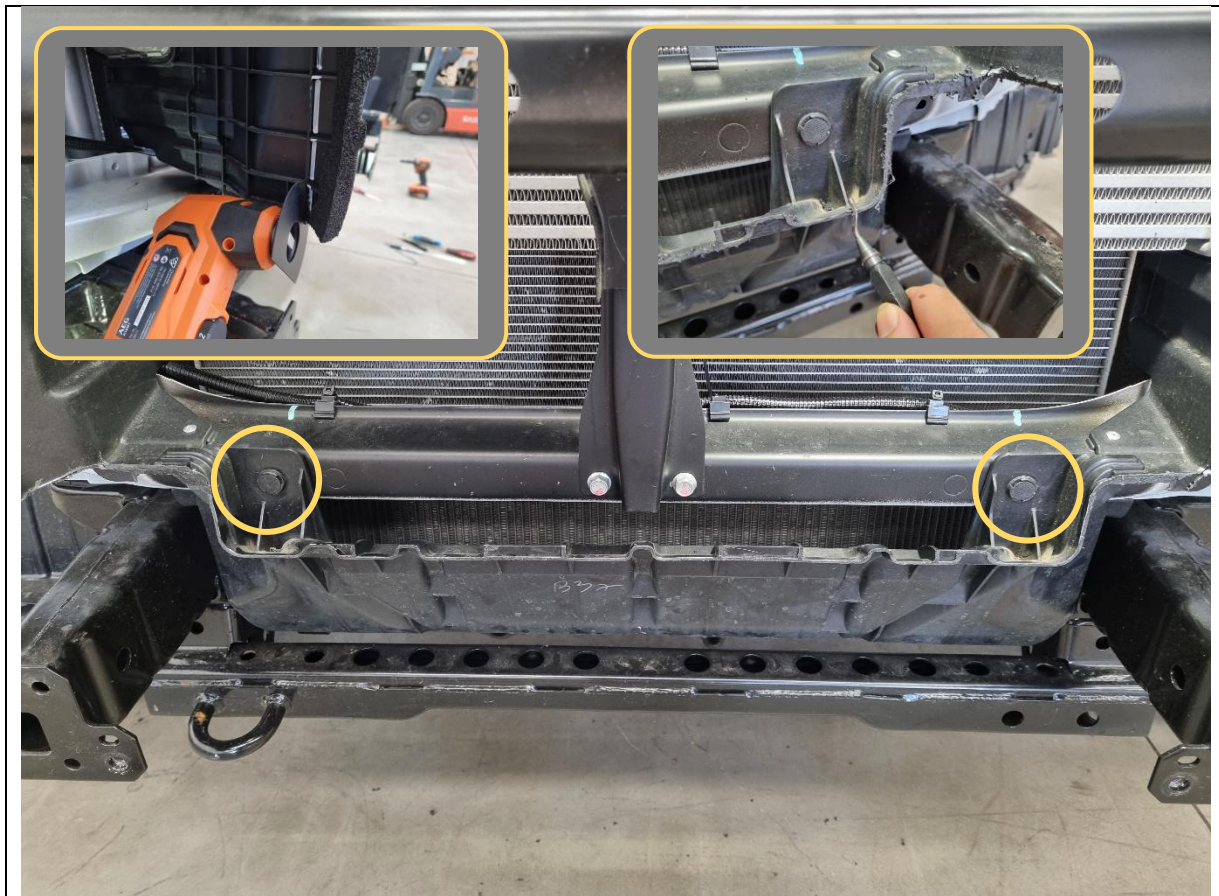

- 39. Trim the plastic air guide with an oscillating multi tool or similar.
- 40. Deburr the trimmed edges.
- 41. Fit the plastic push clips retained from Step 13 back into the holes in the air guide where the light bar bracket was mounted to.

**TOOLS REQUIRED**

- Multi-tool or similar
- Deburring tool or utility knife

**FASTENERS**

- 2x plastic push clips
- Retained from Step 13

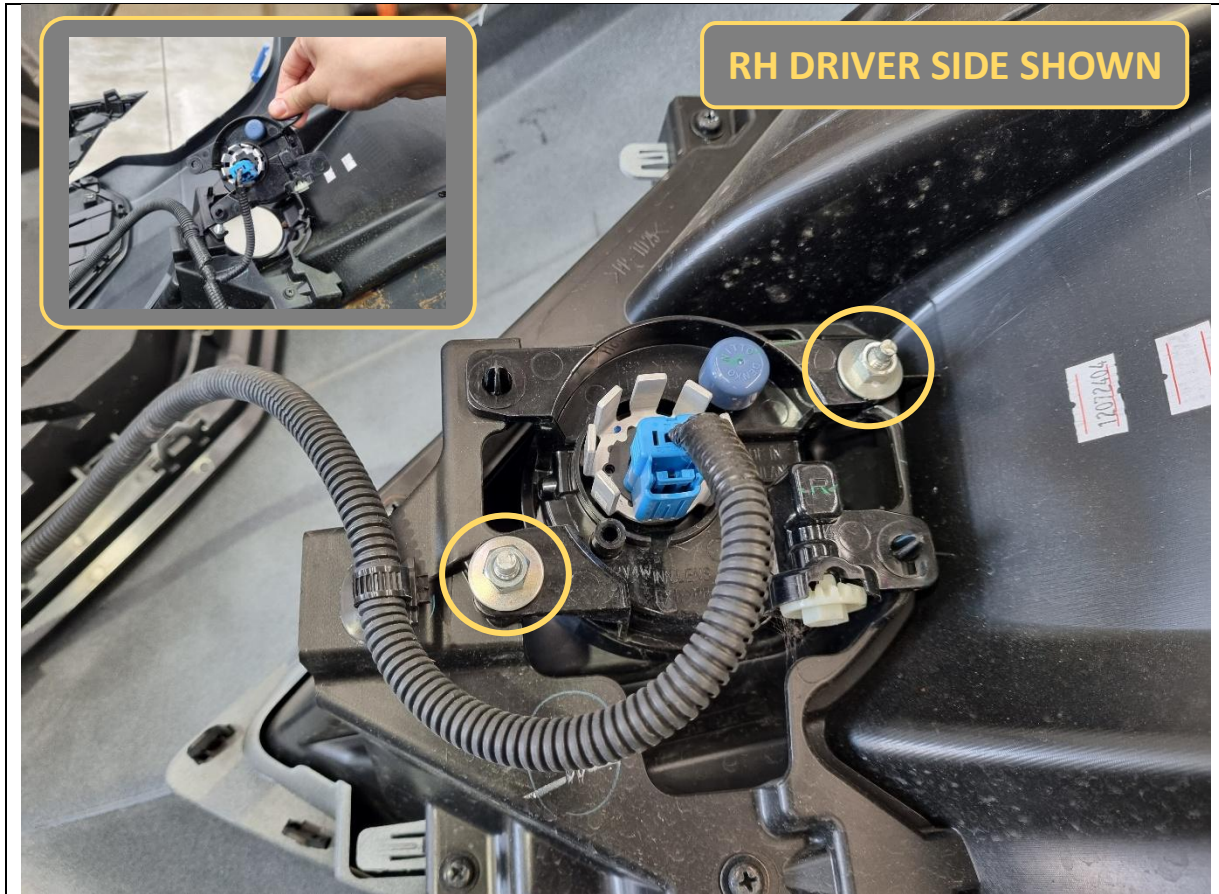

Time to strip the bumper.

- 42. Remove 2x 10mm flange nuts securing each fog light on the back of the bumper.

**TOOLS REQUIRED**

10mm socket/spanner

**FASTENERS**

4x 10mm flange nuts



- 43. Use a side cutter and cut off all the cable tie clips holding the fog light loom to the inside the bumper.
- 44. Separate the fog light and loom and set aside for later.

**TOOLS REQUIRED**

Side cutters

**FASTENERS**

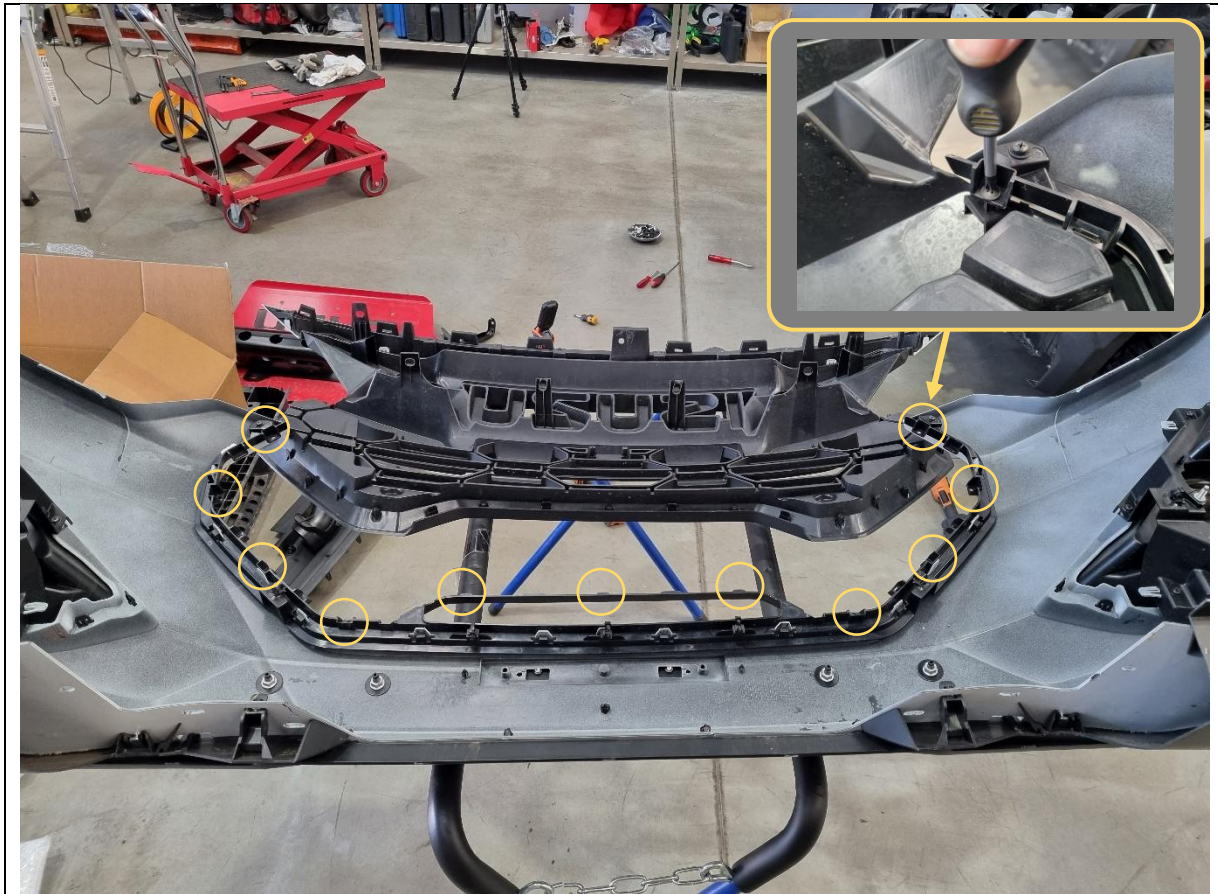

- 45. Remove 11x Phillips head screws holding the grille to the back of the bumper.
- 46. Fully separate the grille from the bumper. Discard the bumper.

**TOOLS REQUIRED**

Phillips head screwdriver

**FASTENERS**

11x factory Phillips head screws

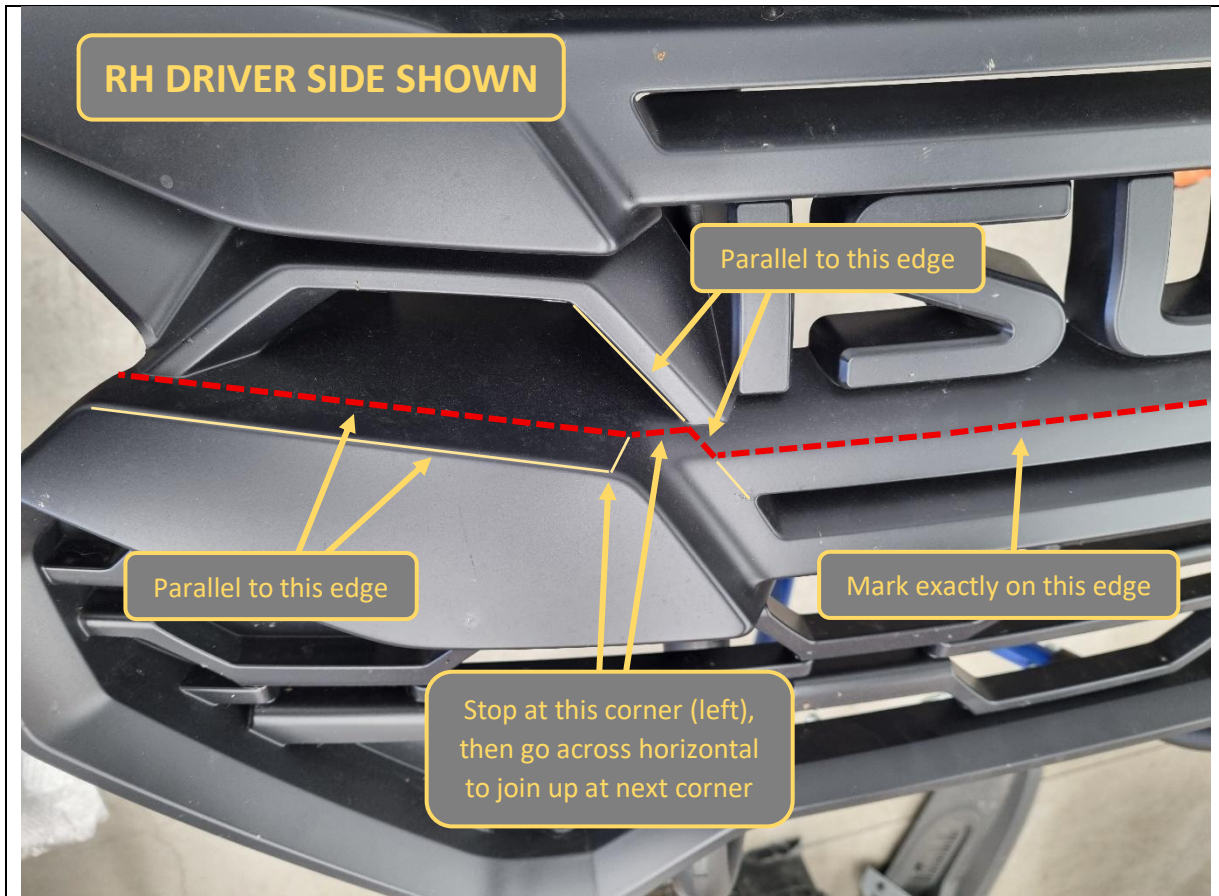

- 47. The lower half of the grille needs to be cut off. Apply masking tape along the cut area.
- 48. Use a marker pen and mark a cut line following notes above. More photos on next page showing cut line.

**TOOLS REQUIRED**

Masking tape  
Marker pen

**FASTENERS**

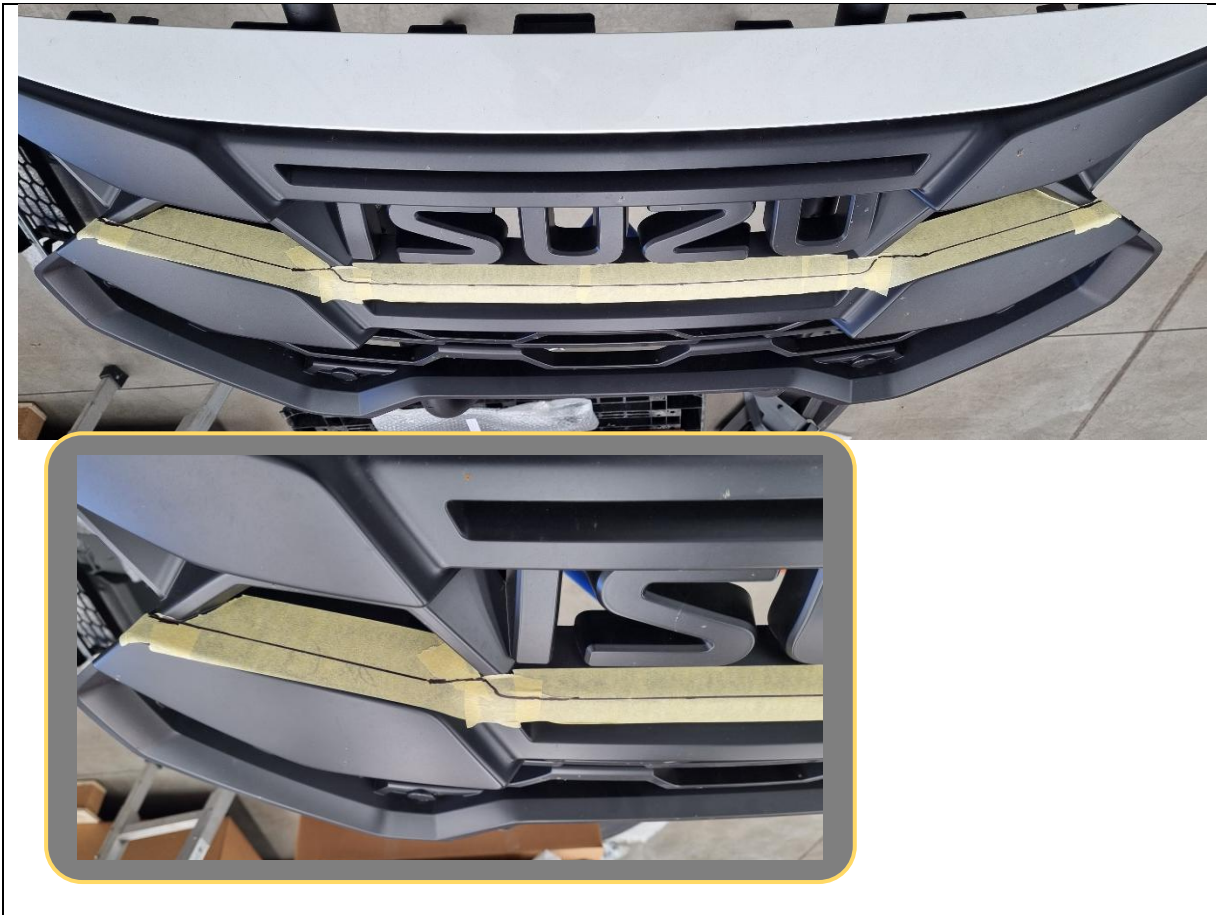

49. More close up photos of the cut line shown.

**TOOLS REQUIRED**

**FASTENERS**

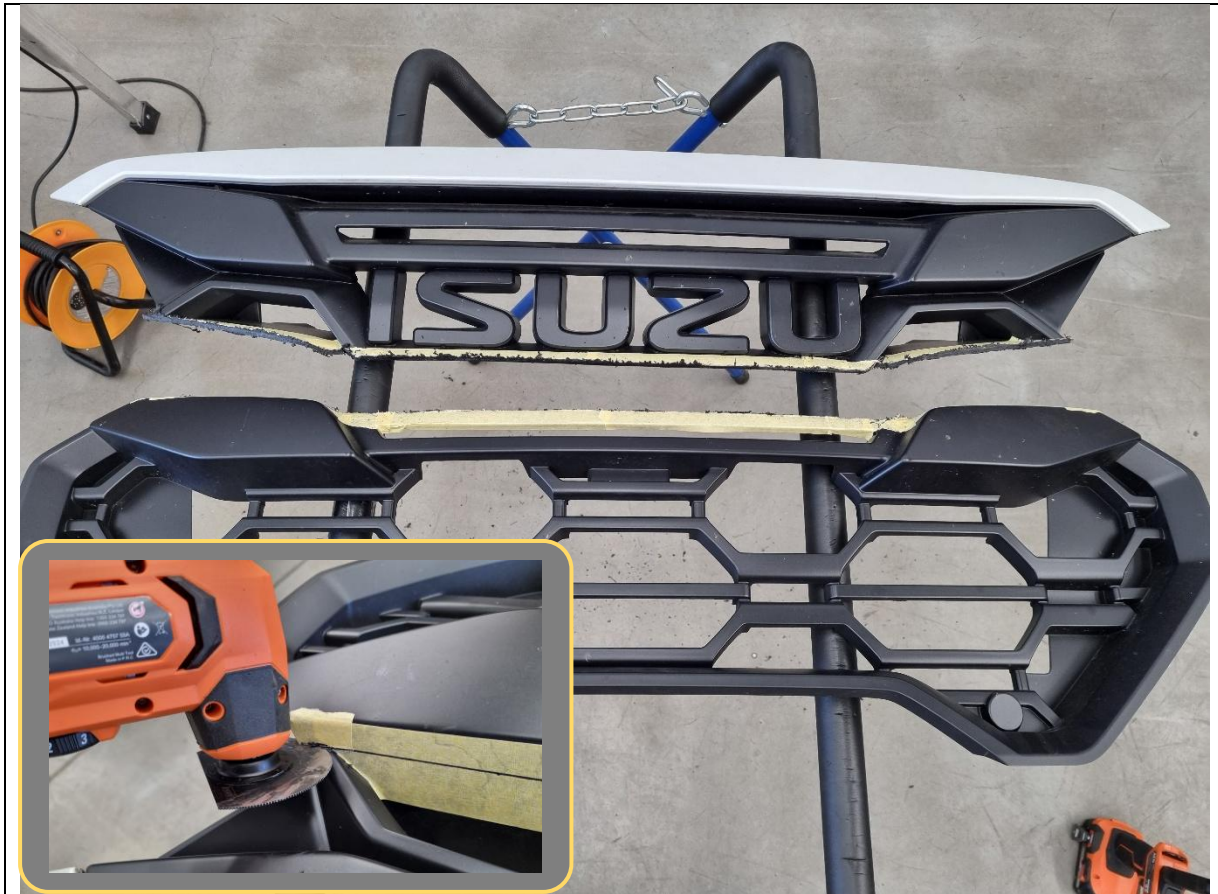

- 50. Trim the grille along the cut line using an oscillating multi-tool or similar device.  
  
Note the plastic is quite thick (around 6mm) and will take some time to cut.
- 51. Discard the lower section.

**TOOLS REQUIRED**

Multi-tool or similar

**FASTENERS**



52. Deburr the trimmed edges.

**TOOLS REQUIRED**

Deburring tool or utility knife

**FASTENERS**



53. Fit 4x M6 cage nuts to the rectangular cutouts in the B-1575 grille mount. Use a flat blade screwdriver to assist.

**TOOLS REQUIRED**

Flat blade screwdriver

**FASTENERS**

4x M6 cage nuts

From Blade small parts kit

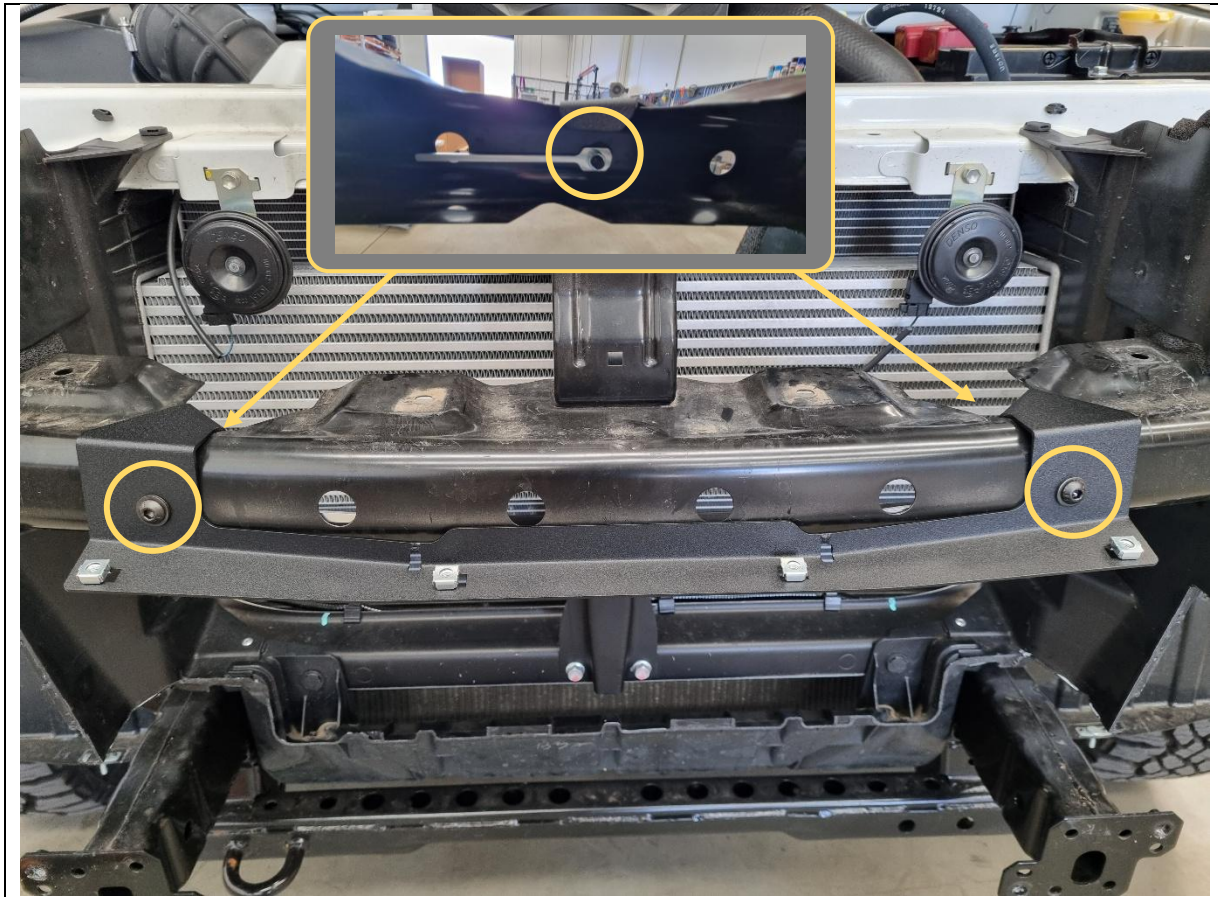

- 54. Fit the B-1575 grille mount to the vehicle as shown.
- 55. Secure using 2x M8x20 black button head bolts, black washers and nutplates (inserted from rear).

**TOOLS REQUIRED**

5mm hex/Allen key

**FASTENERS**

2x M8x20 black button head  
2x M8 black flat washer  
2x 100mm M8 nutplate

From Blade small parts kit

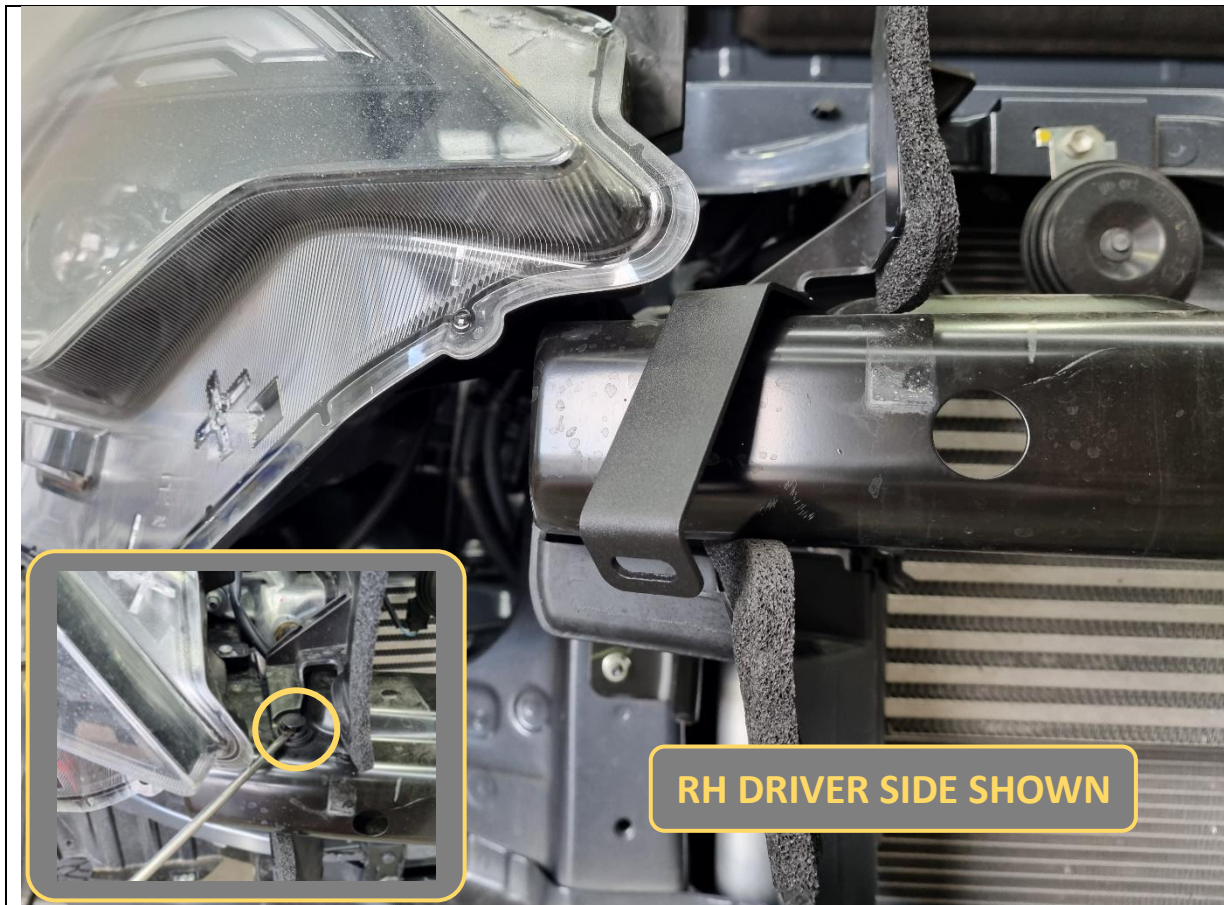

- 56. Remove the 1x plastic push clip holding the upper air guide.
- 57. Fit the B-1296 grille infill brace over the air guide and re-secure using the same plastic push clip.
- 58. Orient the brace in the position as shown above, then repeat for other side.

**TOOLS REQUIRED**

Flat blade screwdriver  
or  
Trim tool

**FASTENERS**



59. Re-fit the grille, radiator grille cover and factory air intake scoop to the vehicle. Secure using original plastic push clips.

**TOOLS REQUIRED**

**FASTENERS**

13x plastic push clips



60. Fit the B-1574 Blade grille infill to the vehicle.

61. Secure at the bottom using 4x M6x16 black button head bolts and black washers, through to the M6 cage nuts already installed in the grille mount.

**TOOLS REQUIRED**

4mm hex/Allen key

**FASTENERS**

4x M6x16 black button head  
4x M6 black flat washer



- 62. Clean the highlighted headlight surfaces with isopropyl alcohol and a rag. You can use a similar weak cleaning solvent but avoid using acetone as it may cause discolouration.
- 63. Also clean the top flange surfaces of the supplied plastic grille infills, as indicated by the arrows in the top left inset image.

**Note:**

If the tape kit comes supplied with a 3M Primer 94 ampoule, break the bulb on it activate primer dispensing. Apply primer to the cleaned surfaces.

**Allow at least 5 minutes for the primer to chemically bond to the surfaces before applying tape (detailed on next page).**

**TOOLS REQUIRED**

Isopropyl alcohol  
Workshop rag

Primer 94 (if supplied)

**FASTENERS**

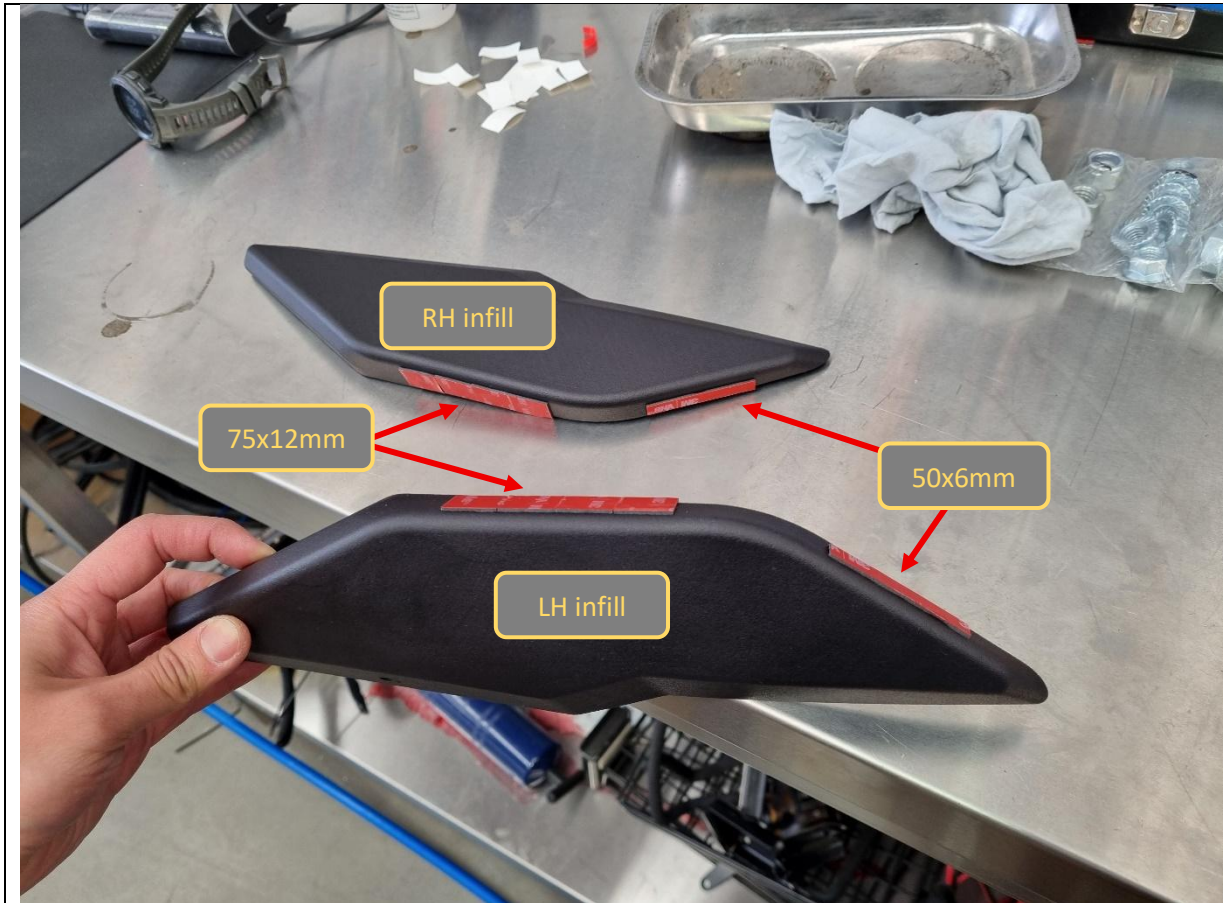

64. Apply supplied 3M VHB tape strips to the 2x grille infills as shown.

**TOOLS REQUIRED**

**FASTENERS**

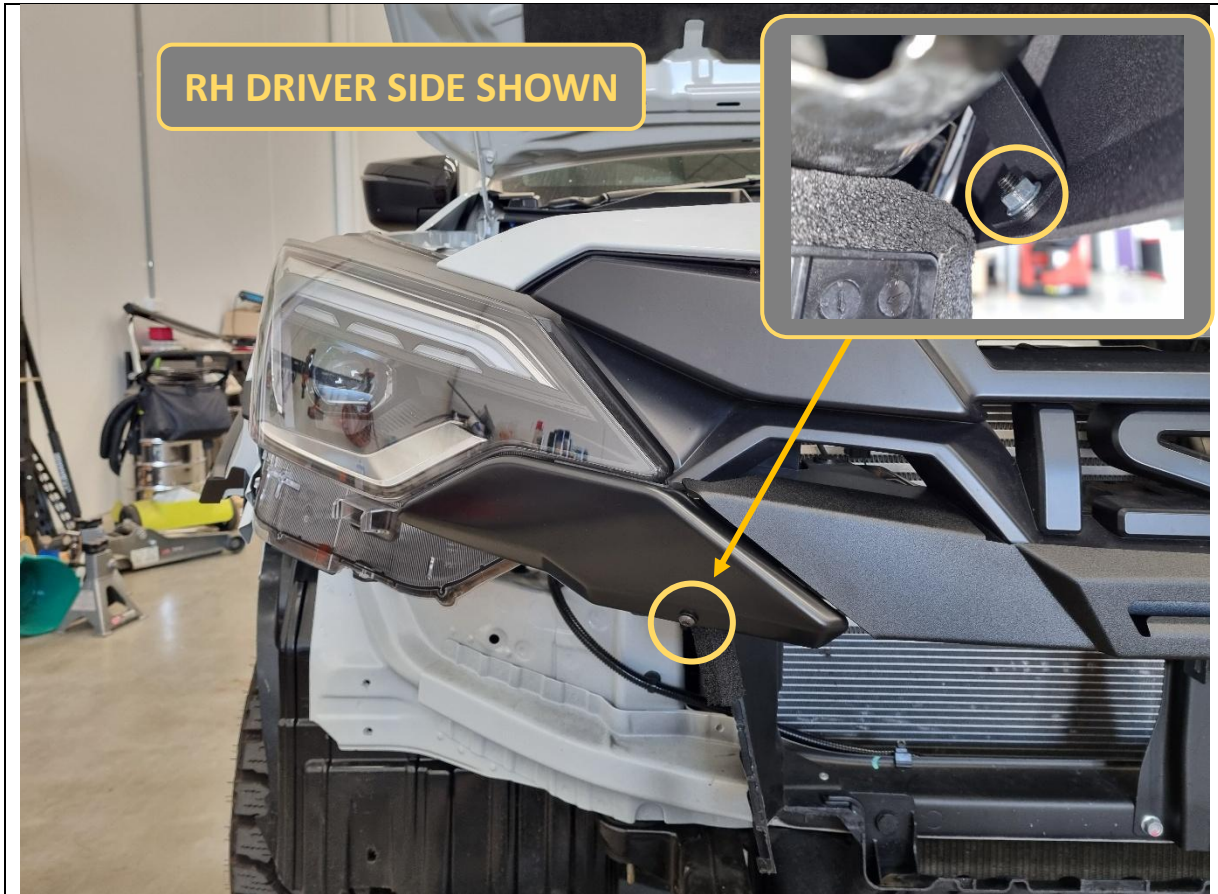

- 65. Peel off the red backing film for the tape strips, then adhere the grille infill to the bottom inside corner of the headlight.
- 66. Hold the infill in place and press firmly up against the headlight for at least 20 seconds for the tape to properly adhere.
- 67. Secure the bottom of the infill to the B-1296 infill brace using 1x M6x16 black button head bolt, black washer and flange nut.
- 68. Repeat for other side.

**TOOLS REQUIRED**

4mm hex/Allen key

**FASTENERS**

2x M6x16 black button head bolt  
2x M6 black flat washer  
2x M6 flange nut



- 69. The flare needs to be cut to match the end of the quarter panel.
- 70. Go to <https://offroadanimal.com.au/dmax-blade-supplementary-kit/> (same place as where these instructions are) and download and print the flare cutting template. Make sure to print on A4 size paper at 100% scale.
- 71. Apply masking tape on to the flare, then use the template to mark out the cut line.

**TOOLS REQUIRED**

Masking tape  
Marker pen

**FASTENERS**



**RH DRIVER SIDE SHOWN**

72. Using an oscillating multi-tool or similar, cut the flare along the marked cut line. Take care not to touch the quarter panel underneath.

If you are not confident cutting the flare whilst it is on the vehicle, you will need to remove it (requires mudflap to also be removed) and source your own double sided foam adhesive tape to reattach it to the vehicle.

73. Ensure you retain the clip hole at the back of the flare (see bottom left inset photo).

74. Repeat the flare cut on the other side.

**TOOLS REQUIRED**

Multi-tool or similar

**FASTENERS**

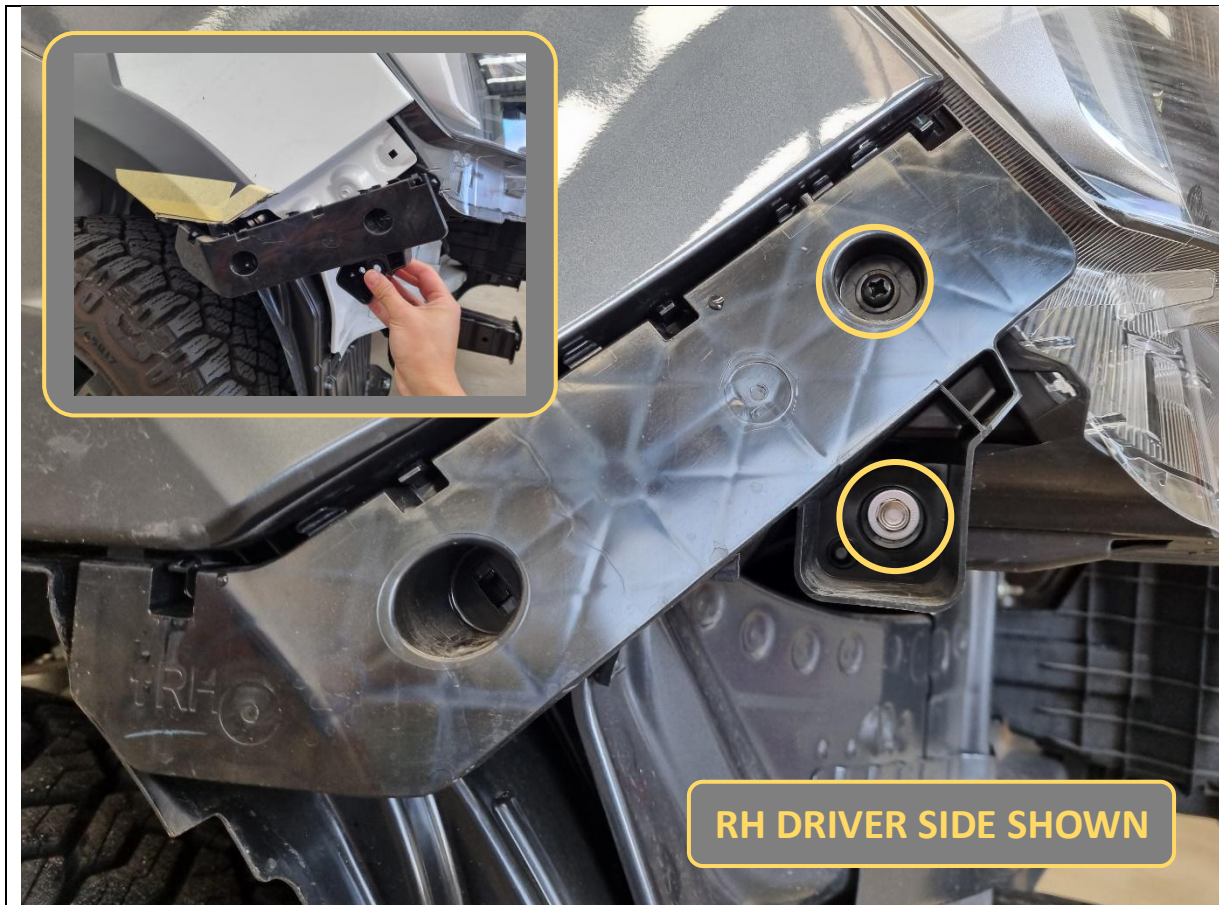

- 75. Once the bottom of the flare has been cut off, remove the 1x 10mm hex bolt and 1x Phillips head screw securing the outer plastic bumper clip. Retain the hex bolt.
- 76. Remove the outer plastic bumper clip. A firm tug will be required to release the clips. Discard afterwards.
- 77. Do this for both sides.

**TOOLS REQUIRED**

Phillips head screwdriver  
10mm socket

**FASTENERS**

2x Phillips head screw (discard)  
2x factory 10mm hex bolt (retain)



78. Tidy up the flare cut and deburr any sharp edges.

79. Clean the flare with isopropyl alcohol or similar weak cleaning solvent (avoid using acetone as it may cause discolouration).

**TOOLS REQUIRED**

Deburring tool  
Isopropyl alcohol  
Workshop rag

**FASTENERS**



- 80. A section of the inner wheel arch liner also needs to be cut off now. Mark out a section as shown above, making sure to retain the clip hole area.
- 81. Use a utility knife or similar and cut the plastic inner wheel arch liner. Deburr any sharp edges.
- 82. Re-fit the plastic push clip retained from Step 17 to re-secure the flare and wheel arch liner to the body.
- 83. Repeat for other side.

**TOOLS REQUIRED**

Utility knife  
Deburring tool

**FASTENERS**

2x plastic push clips  
Retained from Step 17



84. Apply supplied 3M VHB tape strips to the inside of the B-1576 flare endcap as shown. Do this for both LH and RH endcaps.

**TOOLS REQUIRED**

**FASTENERS**



- 85. Peel off the red backing film for the tape strips, then adhere the flare endcap to the outside of the trimmed flare.
- 86. Hold the endcap in place and press firmly up against the flare for at least 20 seconds for the tape to properly adhere.
- 87. Secure the bottom of the endcap to the hole in the quarter panel using 1x M6x12 hex head bolt, flat washer and flange nut. Ensure the bolt head is on the inside and the nut on the outside.
- 88. Repeat for other side.

**TOOLS REQUIRED**

10mm spanner

**FASTENERS**

2x M6x12 hex bolt  
2x M6 flat washer  
2x M6 flange nut



89. Clean the corner of the quarter panel with isopropyl alcohol and a rag, as indicated by the arrow.

90. Also clean the top surfaces of the supplied B-1293 headlight corner infills, as indicated by the arrows in the above inset image.

**TOOLS REQUIRED**

Isopropyl alcohol  
Workshop rag

**FASTENERS**



<p>91. Apply 1x 30x6mm VHB tape strip to each headlight corner infill, as shown.</p> <p>92. Peel off the red backing film for the tape strip, then adhere the headlight corner infill to the quarter panel.</p>	<p><b>TOOLS REQUIRED</b></p> <p>4mm hex/Allen key 10mm socket/spanner</p>
<p>Note the top bolt hole of the infill is fitted <u>behind</u> the quarter panel sheet metal, and the lower bolt hole on the outside of the headlight.</p> <p>93. Hold the infill in place and press firmly up against the quarter panel for at least 20 seconds for the tape to properly adhere.</p> <p>94. Secure the top of the headlight corner infill with 1x M6x16 button head bolt, black flat washer and flange nut. Secure the bottom by re-using the factory 10mm hex bolt into the headlight.</p> <p>95. Repeat for other side.</p>	<p><b>FASTENERS</b></p> <p>2x M6x16 black button head bolt 2x M6 black flat washer 2x M6 flange nut</p> <p>2x factory 10mm hex bolts</p>

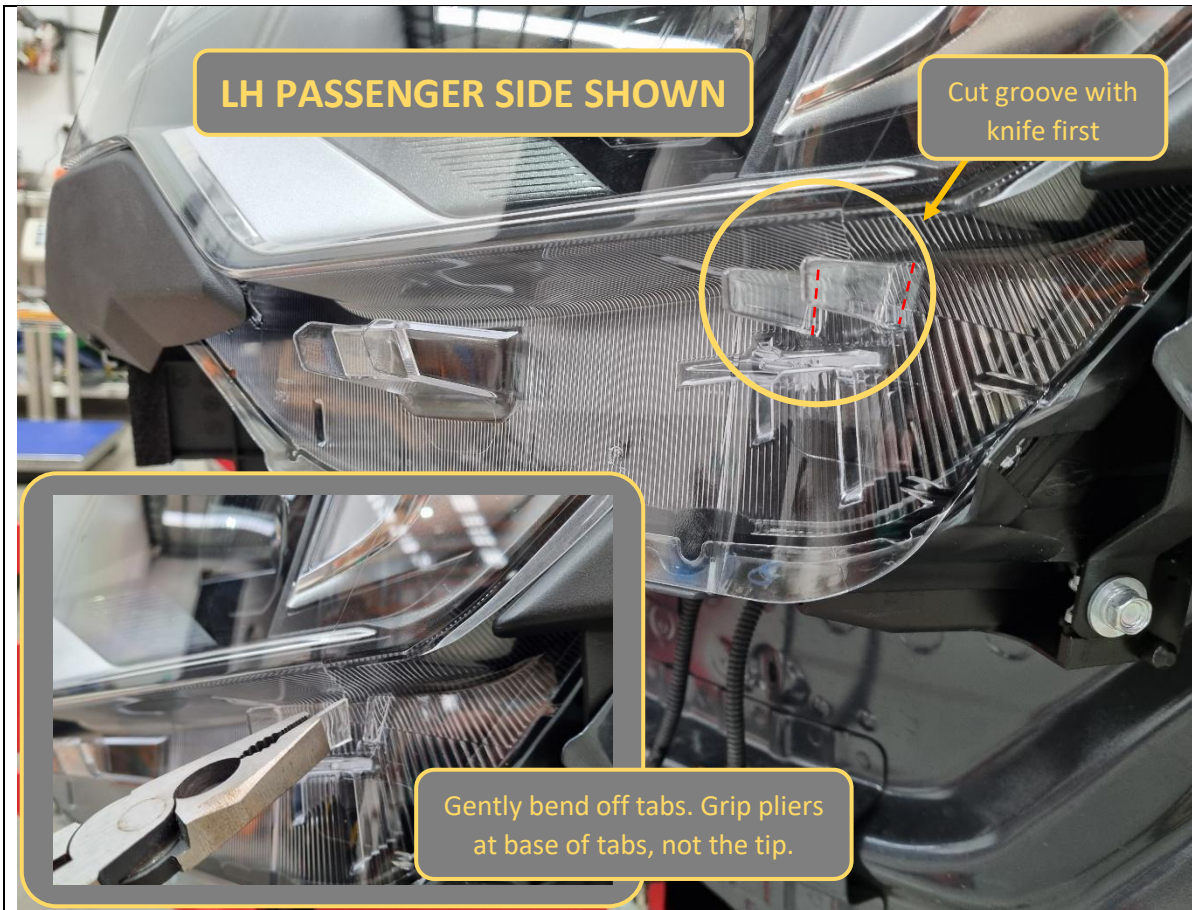

<p>96. Use a utility knife and cut a groove along the base of the outermost plastic tabs under each headlight. (See dashed lines in circled area above)</p> <p>97. Use a pair of pliers to gently snap/bend off the 2x outermost plastic tabs under each headlight. <u>Do not use excessive force.</u></p>	<p><b>TOOLS REQUIRED</b></p> <p>Utility knife Pliers</p>
	<p><b>FASTENERS</b></p>

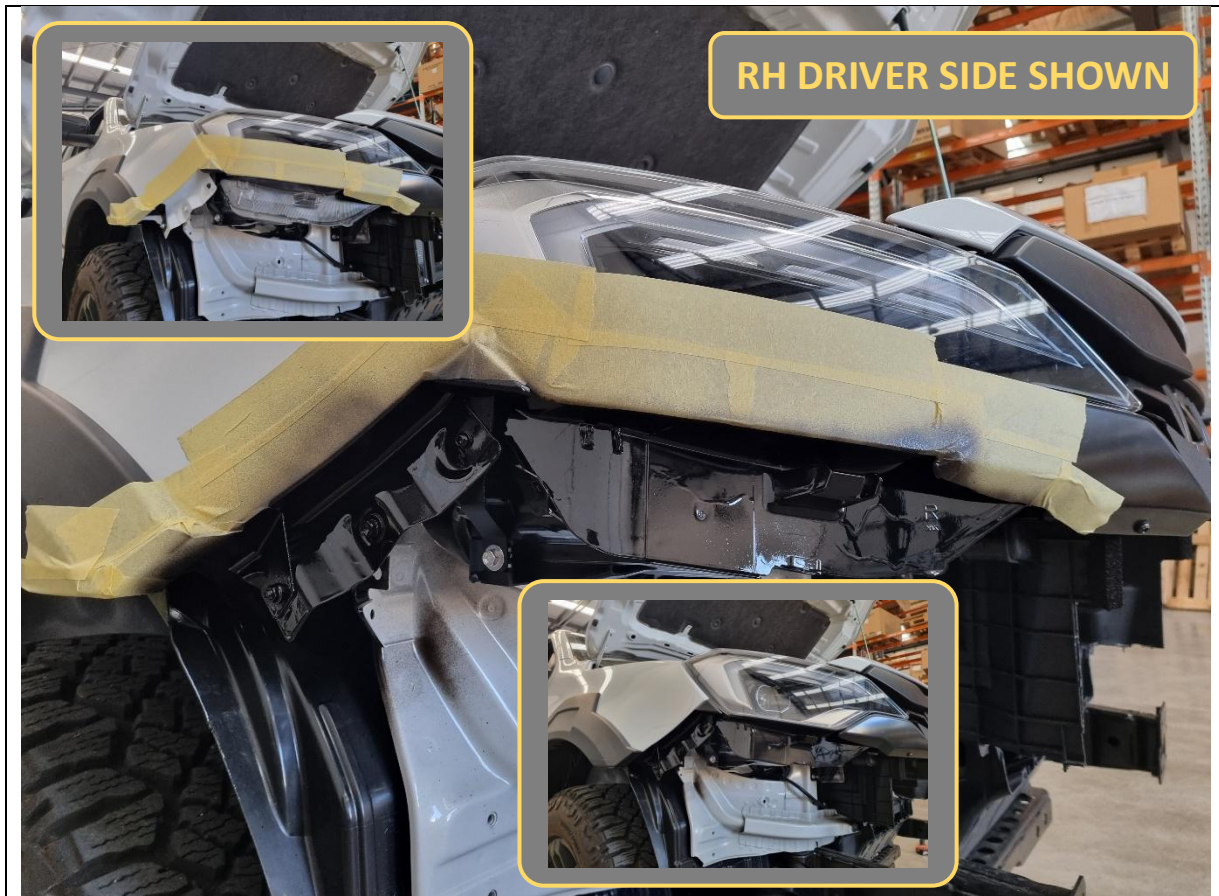

- 98. It is recommended to paint black the underside of the headlight and the guard.
- 99. Clean the surfaces to be painted and mask off the quarter panel, infills and headlights. Then use black spray paint and paint the area black.
- 100. Remove the masking tape and allow the paint to dry before fitting the bull bar.

**TOOLS REQUIRED**

Masking tape  
Black spray paint

**FASTENERS**

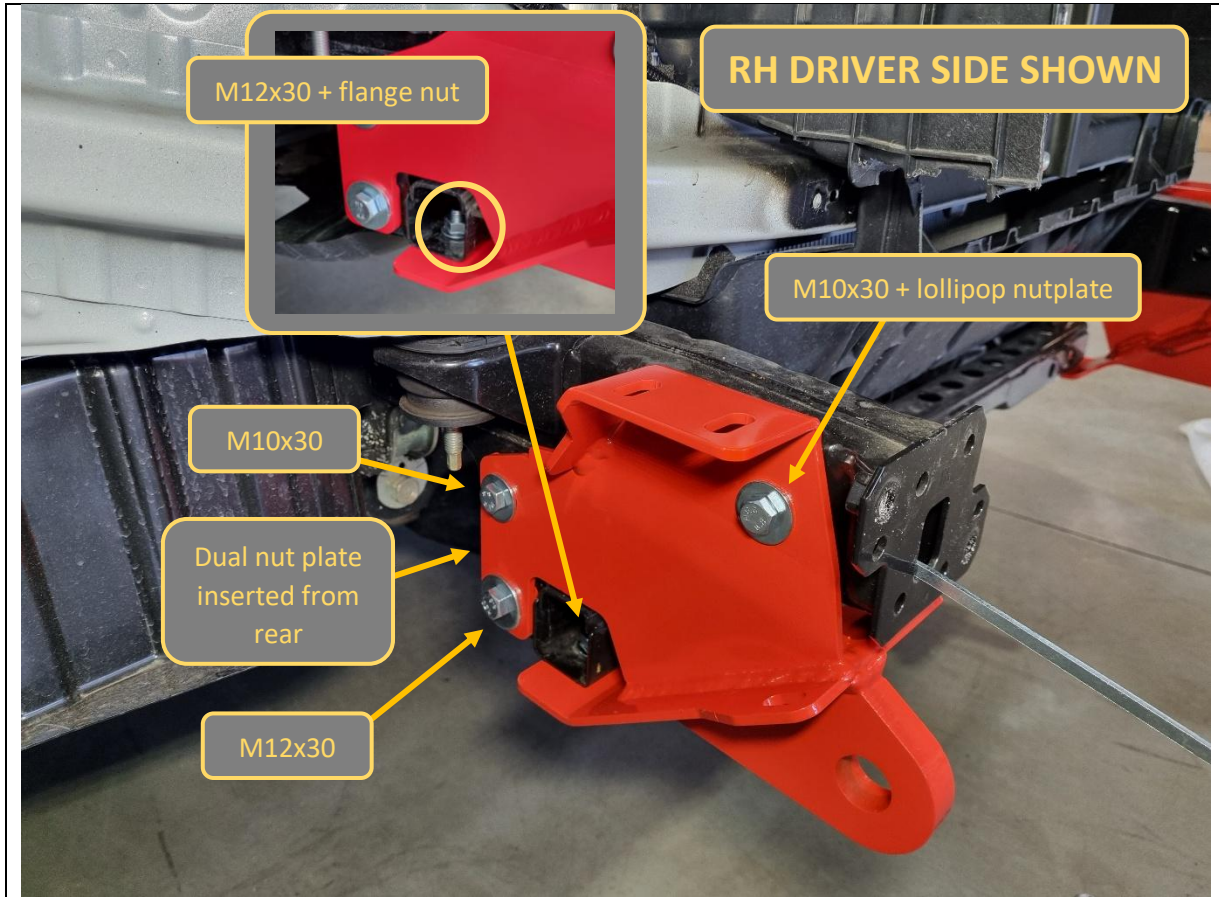

101. Fit the tow point to the outside of the chassis rail.
102. Loosely secure the bottom of the tow point to the horizontal chassis cross member with 1x M12x30 hex bolt, heavy-duty washer and flange nut.
103. Insert 1x M10 lollipop nutplate through the front opening of the chassis rail, then loosely secure to the tow point with 1x M10x30 hex bolt and heavy-duty washer.
104. Insert the dual nutplate through the back of the chassis drop member and loosely secure to the tow point with 1x M12x30 hex bolt, 1x M10x30 hex bolt and heavy-duty washers.
105. Repeat for other tow point.

**TOOLS REQUIRED**

**FASTENERS**

- 4x M10x30 hex bolt
- 4x M10 heavy-duty washer
- 4x M12x30 hex bolt
- 4x M12 heavy-duty washer
- 2x M12 flange nut
- 2x M10 lollipop nutplate
- 2x dual nutplate

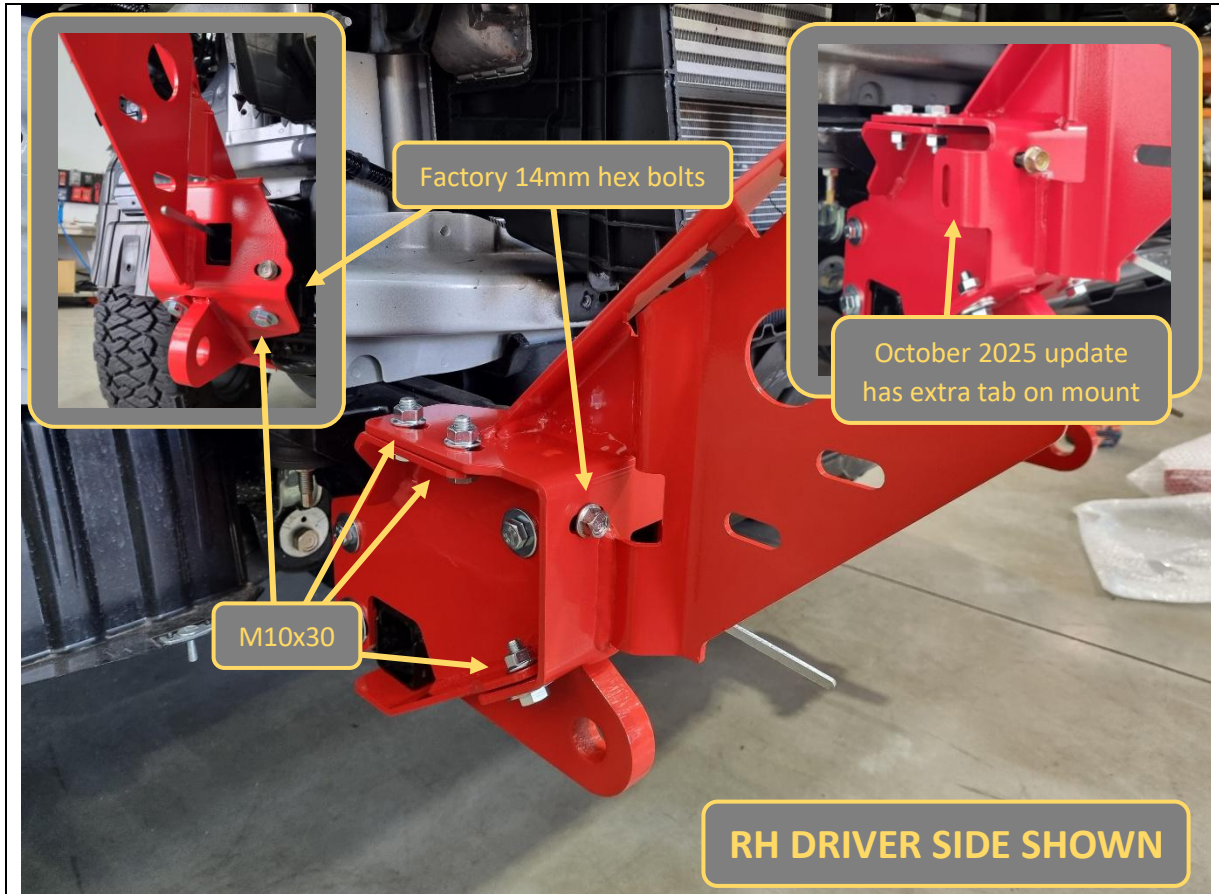

- 106. Fit the impact assembly to the chassis and loosely secure using 2x factory 14mm hex bolts retained from the crash beam.
- 107. Secure to the impact assembly to the tow point using 4x M10x30 hex bolts, heavy-duty washers and flange nuts as shown.
- 108. Repeat for both sides of vehicle. Leave all bolts in the tow points and impact assemblies finger tight at this stage.

**TOOLS REQUIRED**

**FASTENERS**

- 4x factory 14mm hex bolt
- 8x M10x30 hex bolt
- 8x M10 heavy-duty washer
- 8x M10 flange nut

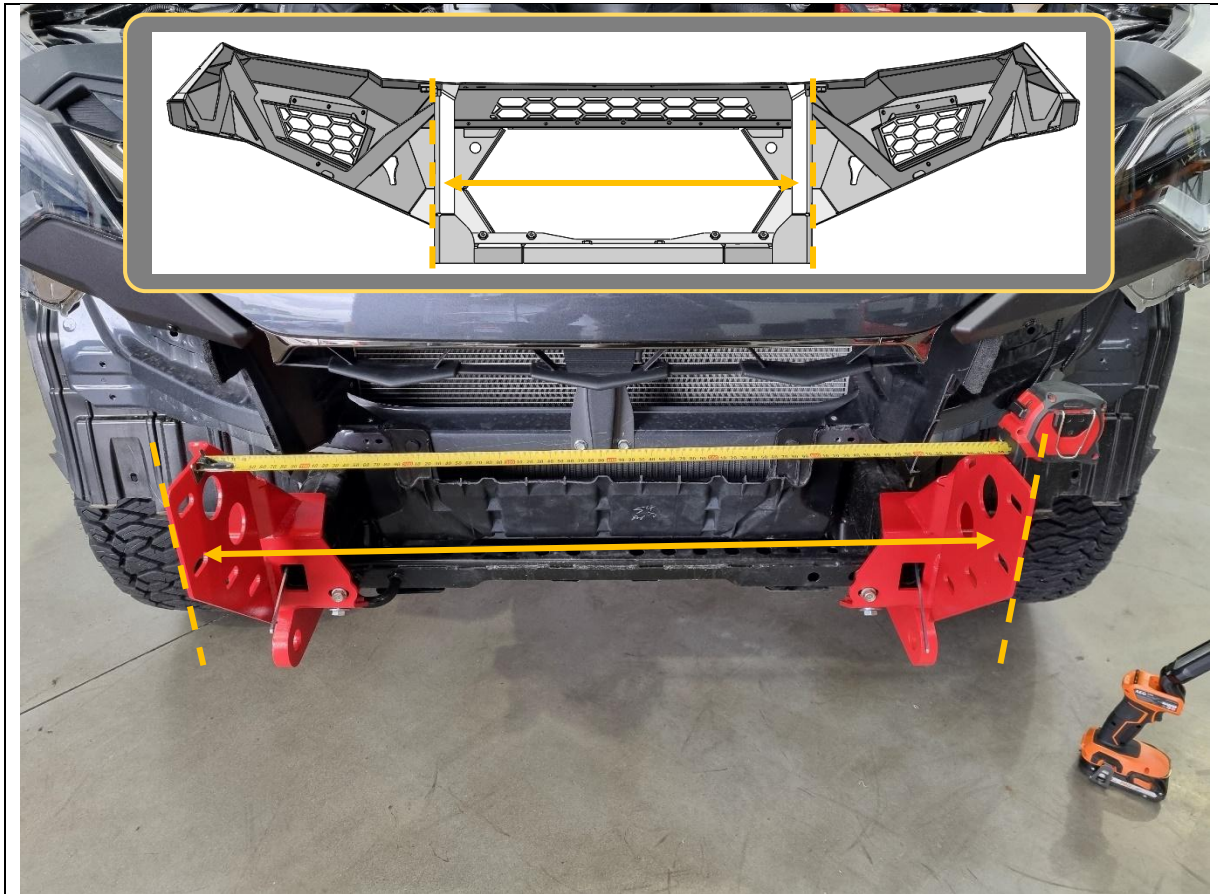

109. Measure the distance between the outside faces of uprights on bar using tape measure. Write distance below for reference if required.

Bar Upright Width = \_\_\_\_\_mm

110. Adjust mounts by sliding left/right on the slots, such that distance between inner faces of mounts are 2-5mm more than bar. Ensure the mount faces are vertically upright and symmetric left/right on the chassis.

111. Tighten all bolts securing impact assemblies and tow points.

112. Re-check the distance and re-adjust as required.

**TOOLS REQUIRED**

Tape measure

14mm socket/spanner

16mm socket/spanner

19mm socket/spanner

**FASTENERS**

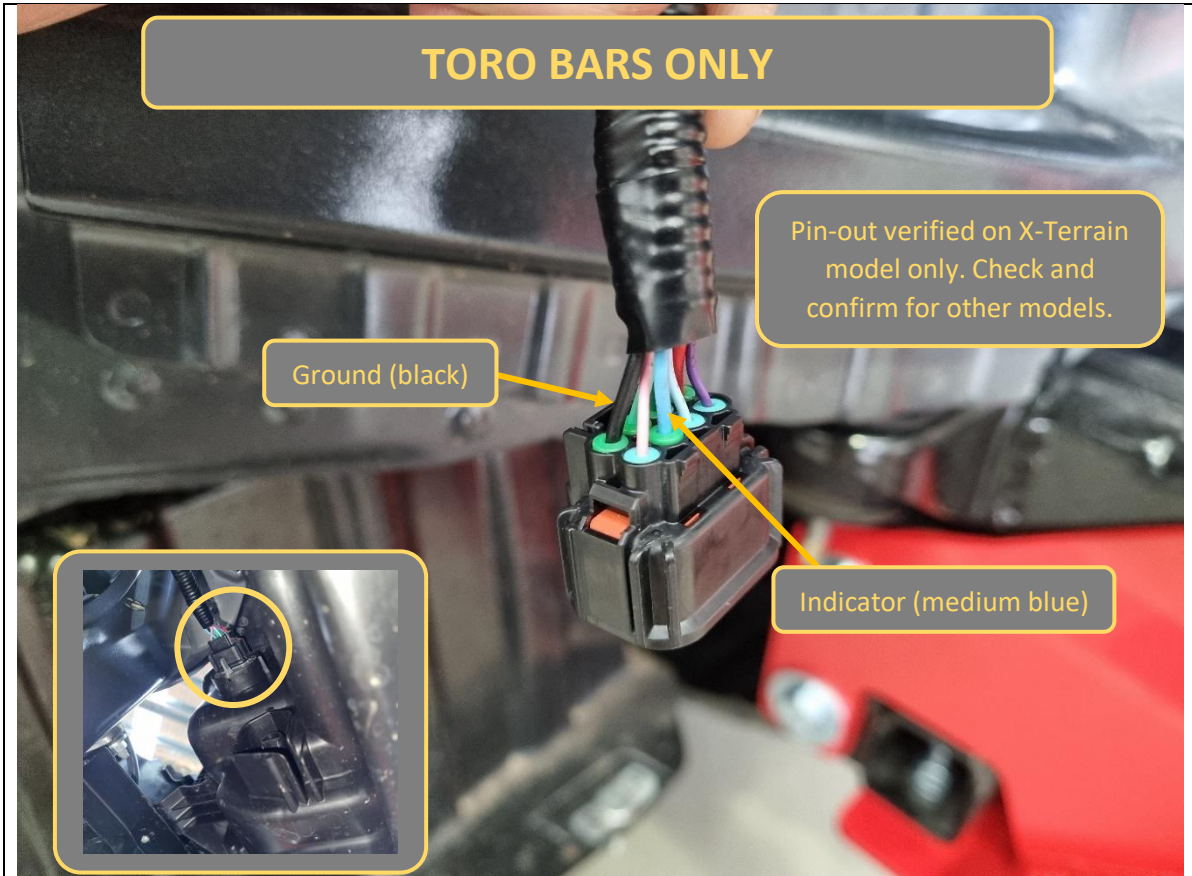

<p>113. <b>Toro only.</b> Locate the plug on the back of each headlight and disconnect.</p> <p>114. <b>Toro only.</b> Probe with a test light to confirm indicator signal and ground. On X-Terrain models, the wiring pinout is as follows:</p> <p>Medium blue = Indicator signal Black = Ground</p> <p>115. <b>Toro only.</b> Splice and solder automotive electrical wires into the harness for indicator signal and ground. Use heat shrink or electrical tape to insulate solder connections. Do this for both LH and RH indicators, then re-connect headlights.</p>	<p><b>TOOLS REQUIRED</b></p> <p>Cutting pliers Wire strippers Soldering iron Solder Automotive electrical wire Heat shrink Heat gun Electrical tape</p>
<p><b>OCTOBER 2025 UPDATE</b> There is now an optional high beam/indicator plug and play piggyback harness available to purchase. Part number: CAT6-IDMB-Q</p>	<p><b>FASTENERS</b></p>



<p>116. <b>Toro only.</b> Fit indicator units to the indicator mounting bracket, using fasteners supplied with the indicator.</p>	<p><b>TOOLS REQUIRED</b></p> <p>Refer to instructions supplied with indicators</p>
	<p><b>FASTENERS</b></p> <p>Supplied with indicators</p>



<p>117. <b>Toro only.</b> Fit the indicator and bracket to the inside of the bullbar wing.</p> <p>118. <b>Toro only.</b> Secure with 3x M6x16 button head bolts, black washers and flange nuts.</p> <p>119. <b>Toro only.</b> Repeat for other side.</p>	<p><b>TOOLS REQUIRED</b></p> <p>4mm hex/Allen key</p>
	<p><b>FASTENERS</b></p> <p>6x M6x16 black button head bolt 6x M6 black flat washer 6x M6 flange nut</p>

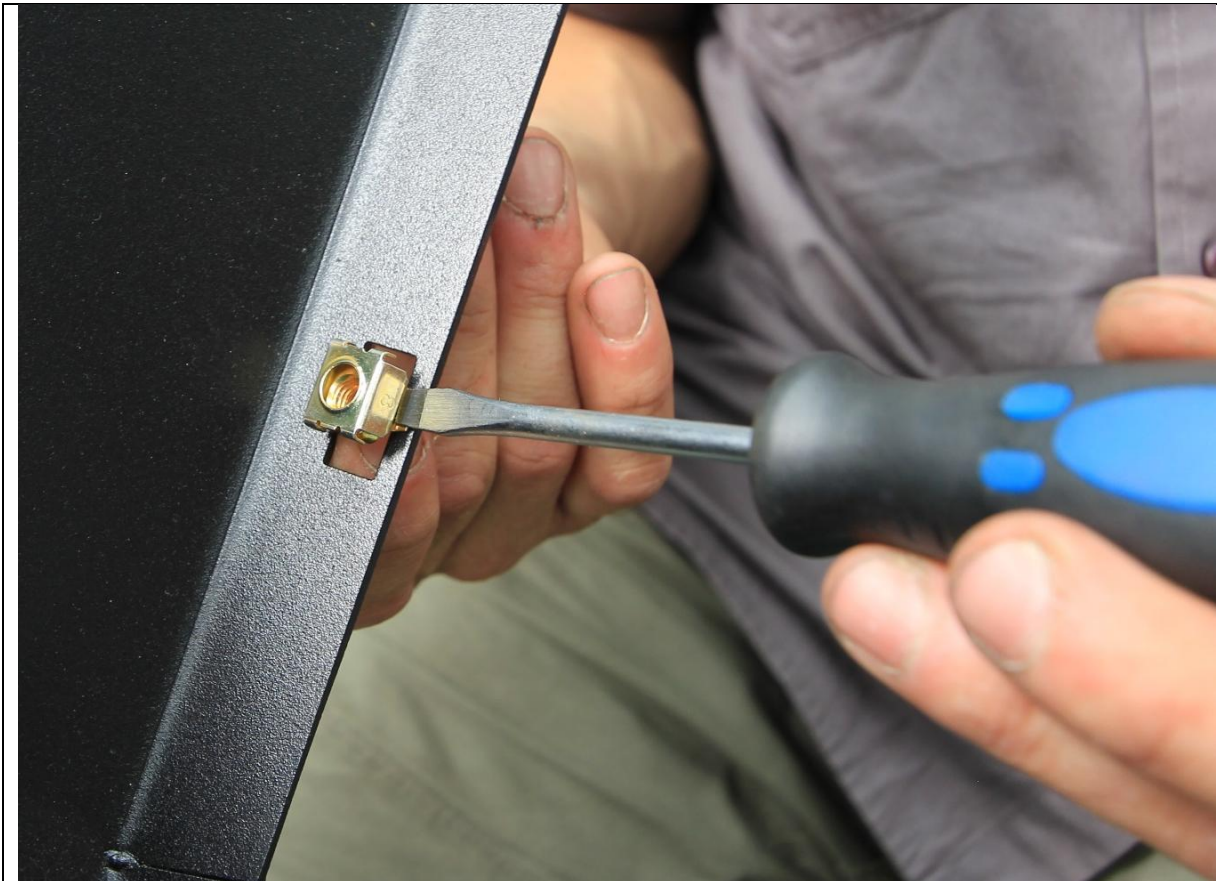

120. Fit 10x M6 cage nuts into the rectangular slots in bottom of wing (5x per side)

Use a small flat blade screwdriver to push the edge of the cage to engage with the slot to aid fitting.

**TOOLS REQUIRED**

Flat blade screwdriver

**FASTENERS**

10x M6 cage nuts



<p>121. If fitting an integrated light bar, do so now.</p> <p>This bar is designed to fit the Offroad Animal 22-inch light bar. If fitting this light bar, assemble the light bar with legs facing outwards, and line it up with the slots in the centre gusset. Secure with M6 fasteners supplied with the light.</p> <p>This bar can accommodate most other “20-22inch” size single row light bars. Stedi ST3K light bars require legs facing inwards.</p>	<p><b>TOOLS REQUIRED</b></p> <p>Supplied with accessories</p>
<p>122. If fitting driving lights, stealth hoop, round hoop or rally hoop to this bar, this is also the most convenient time to do so. It is still possible later but is more difficult.</p>	<p><b>FASTENERS</b></p> <p>Supplied with accessories</p>



123. Route the fog light bumper wiring harness through the inside of the bullbar.

Use the provided cutouts up near where the light bar mounts to route through.

If required, temporarily disconnect fog lights to route through.

Ensure the harness is orientated correctly, with the plug connecting to the vehicle on the LH side.

**TOOLS REQUIRED**

**FASTENERS**

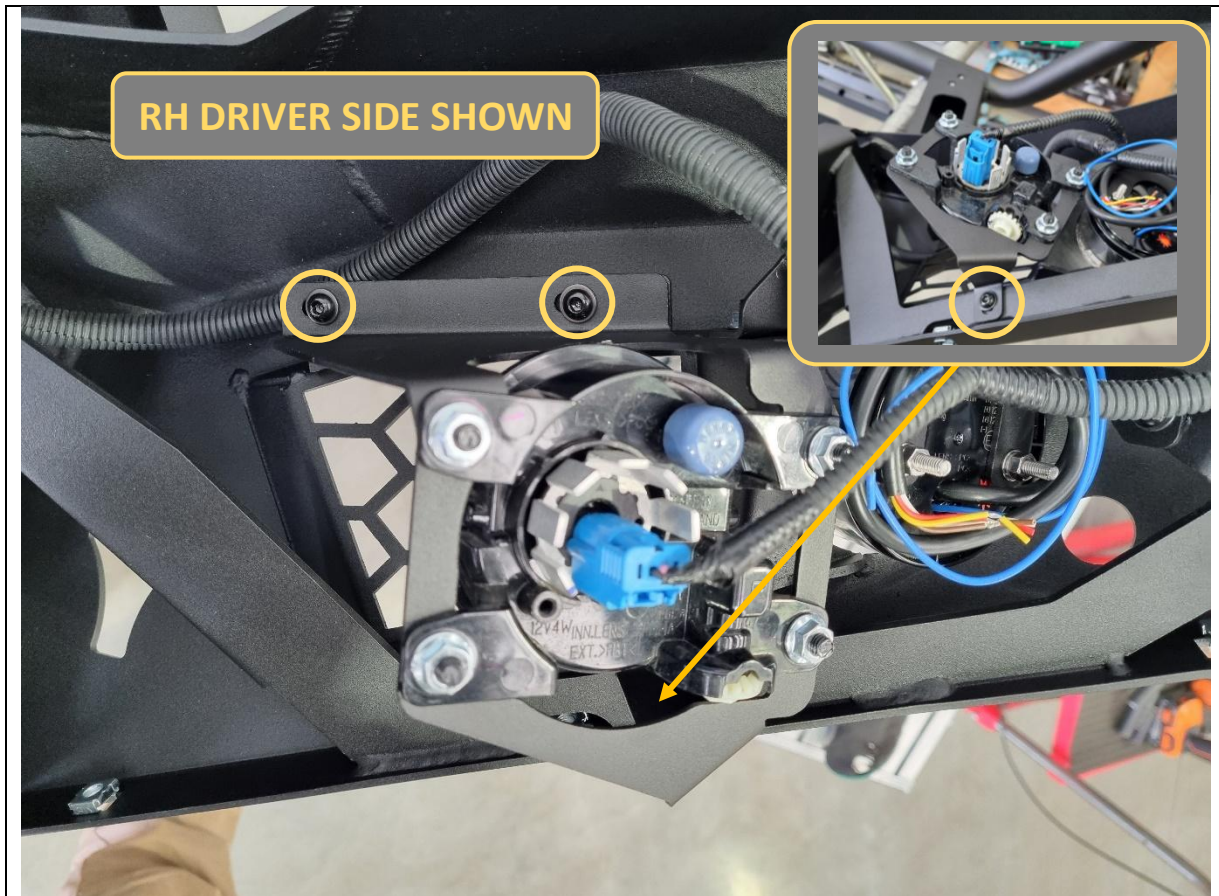

- 124. Fit the fog lights to the supplied mounting bracket and secure with 4x M6x16 black button head bolts, black washers and flange nuts.
- 125. Then fit the fog light and mounting bracket to the inside of the bullbar wing, and secure with 3x M6x16 black button head bolts and black washers.
- 126. Repeat for other side.

**TOOLS REQUIRED**

4mm hex/Allen key

**FASTENERS**

14x M6x16 black button head bolt  
14x M6 black flat washer  
8x M6 flange nut



<p>127. Fit the pan brace to the back of the top centre section of the bullbar.</p> <p>128. Secure the bottom of the pan brace to the back of the bar with 3x M6x16 black button head bolts and black washers.</p> <p>129. Secure the top of the pan brace to the top face of the bar with 2x M6x16 black button head bolts, black washers and flange nuts.</p>	<p><b>TOOLS REQUIRED</b></p> <p>4mm hex/Allen key</p>
	<p><b>FASTENERS</b></p> <p>5x M6x16 black button head bolt 5x M6 black flat washer 2x M6 flange nut</p>



130. Insert the supplied plastic round blanking plugs into all 4x parking sensor holes in the bullbar.

**TOOLS REQUIRED**

**FASTENERS**



<p>131. <b>Toro only.</b> If required, fit the supplied antenna mounting brackets to the back of the bar, and secure with 2x M8x20 black button head bolts and black washers, each.</p>	<p><b>TOOLS REQUIRED</b></p> <p>5mm hex/Allen key</p>
<p>132. <b>Toro only.</b> Else fit the 2x M8x20 black button head bolts and black washers to the back of each bullbar upright, to protect nut threads in bar for future use.</p>	<p><b>FASTENERS</b></p> <p>4x M8x20 black button head bolt 4x M8 black flat washer</p>



133. Fit the supplied lengths of side bulb pinch weld rubber to the outermost edge of the wing on each side of the bullbar.

134. Trim to length if required.

**TOOLS REQUIRED**

Side cutters

**FASTENERS**

2x side bulb pinch weld rubber

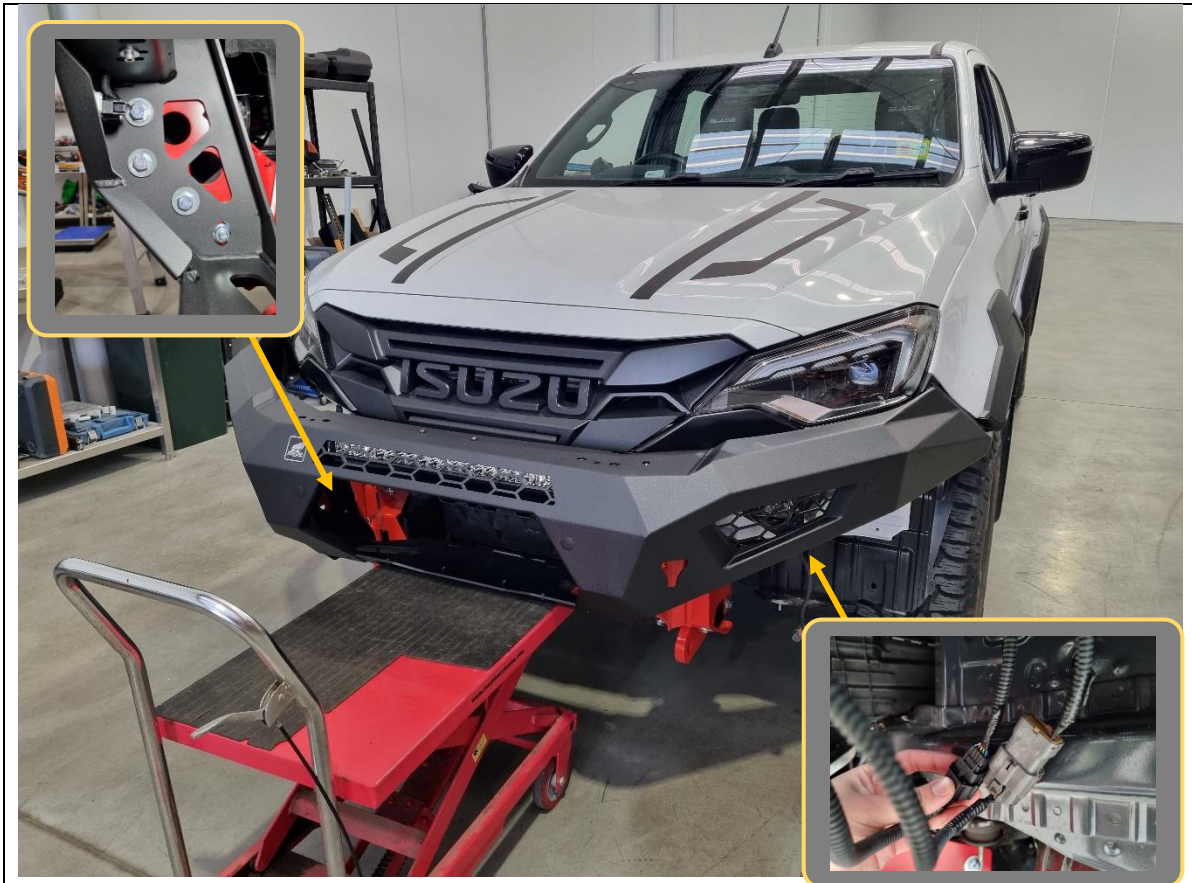

135. With assistance, either from another person or a lifting trolley, lift the bar onto the mounts on the vehicle.

136. Secure the bar to the mounts with 8x M12x30 bolts, heavy-duty washers and Nyloc + flange nuts. Leave finger tight at this stage.

Note: Use a washer on both bolt and nut side for the Nyloc nut. 1x Nyloc required per side of the bar. 1x washer on the bolt side is all that is required with flange nuts.

137. Re-connect the fog light bumper harness connector back to the vehicle.

138. **Toro only.** Connect the indicator repeater lamps to the vehicle headlight harness (solder/crimp together, ensure well insulated).

**TOOLS REQUIRED**

Lifting trolley

**FASTENERS**

8x M12x30 hex bolt  
10x M12 heavy duty washer  
2x M12 Nyloc nut  
6x M12 flange nut

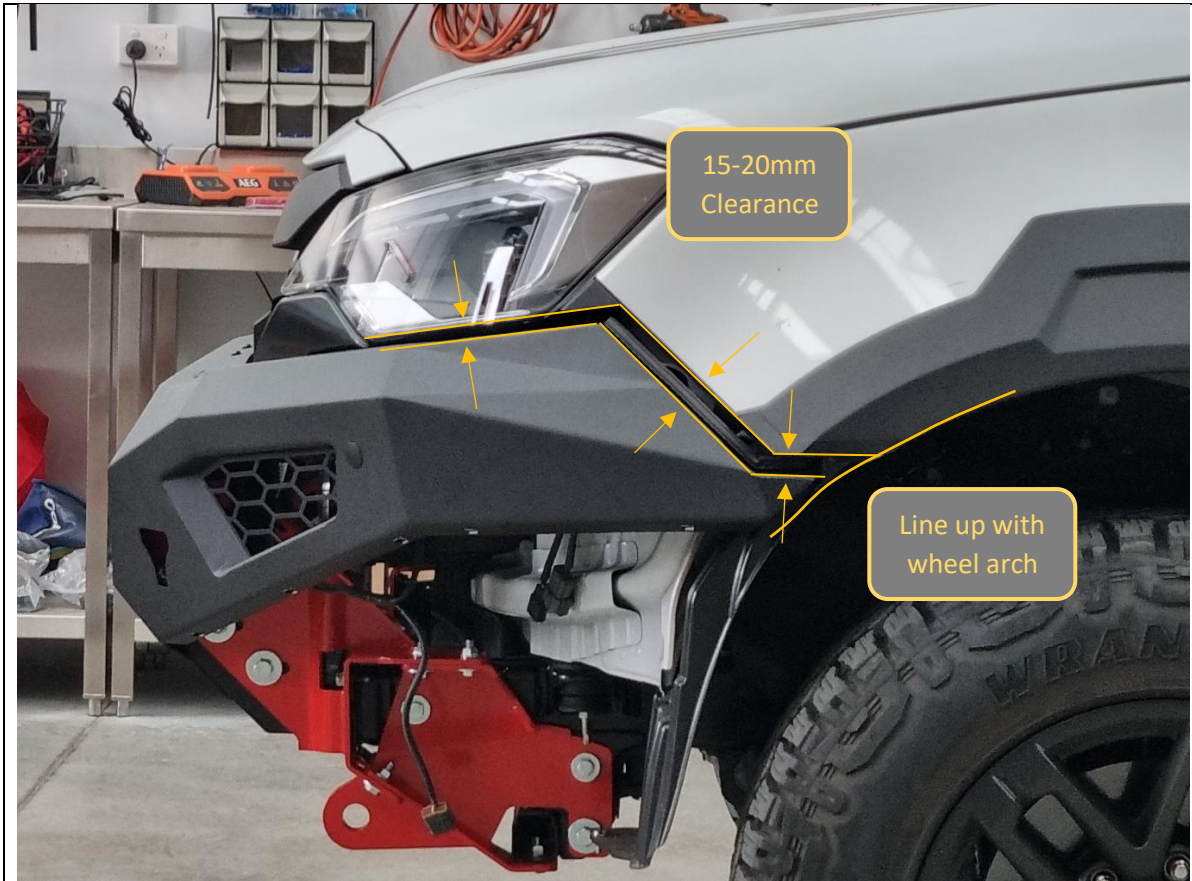

139. With assistance, from another person, align the bar with the edges of the vehicle. Adjust such that the clearances are neat, and the bar is symmetric left/right on the vehicle.

Acceptable range of clearances are outlined below. **Ensure clearances are maintained all the way through below the headlight.**

Front view: the bar should sit horizontally level with the body.

Side view: the bar should have 15-20mm vertical clearance to the quarter panel and headlight. The end of the bar wing should be in line with the wheel arch liner.

Top view: there should have 10-15mm clearance between the bar and grille.

140. Once happy with alignment, tighten all 8x M12 bolts.

**TOOLS REQUIRED**

- Lifting Trolley
- 18/19mm socket/spanner

**FASTENERS**



<p>141. If fitting a winch, do so now.</p> <p>142. This bar is designed to fit most low mount winches, in foot down configuration. WARN ZEON 12 is the largest winch confirmed to fit.</p> <p>143. Ensure clutch handle will be accessible through opening in front mesh panel. Refer to winch instructions regarding changing clutch handle location.</p>	<p><b>TOOLS REQUIRED</b></p> <p>Refer to instructions supplied by winch</p>
	<p><b>FASTENERS</b></p> <p>Supplied with winch</p>

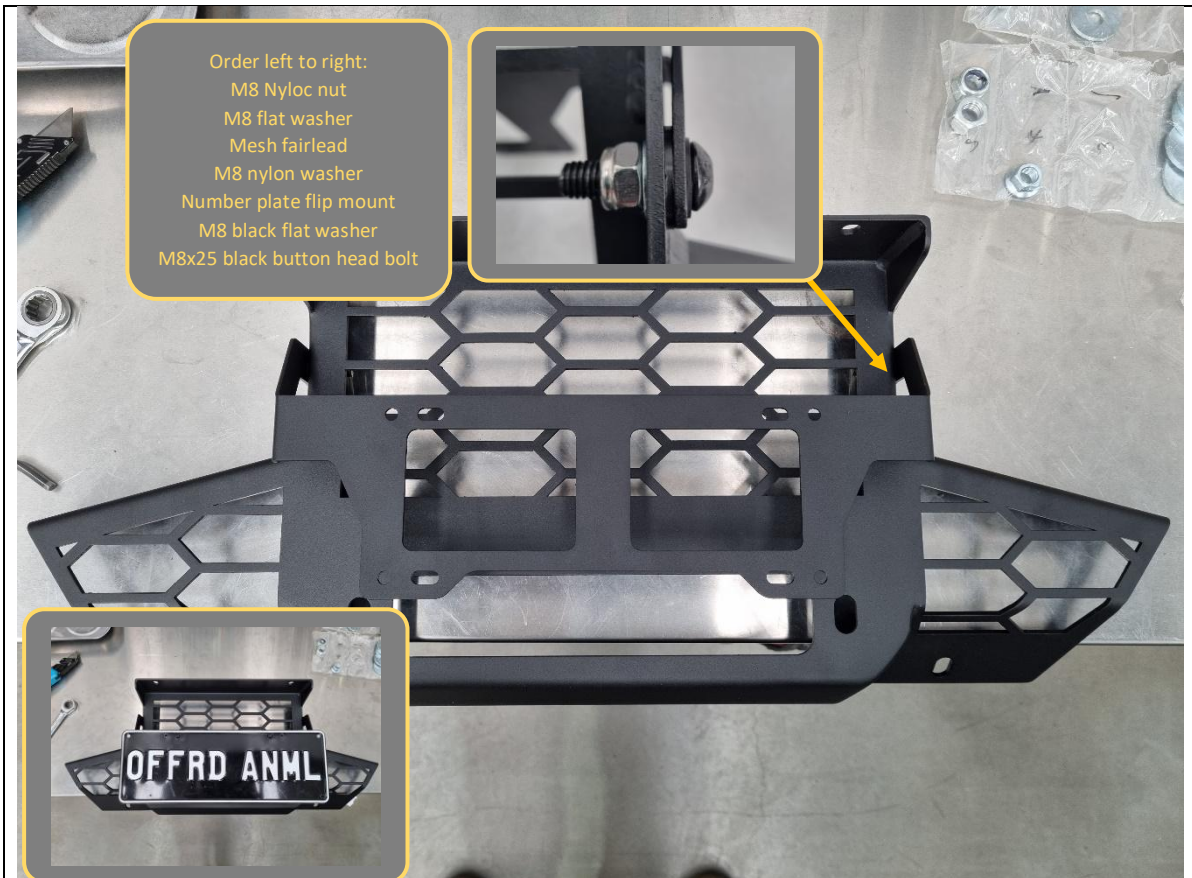

- 144. Fit number plate flip mount to mesh panel as shown above. Tighten bolts so that flip mount and can be moved by hand with some friction resistance.
- 145. Attach number plate to mount using 2x M6x16 black button head bolts, black washers and flange nuts.

**TOOLS REQUIRED**

- 5mm hex/Allen key
- 13mm socket/spanner
- 4mm hex/Allen key

**FASTENERS**

- 2x M8x25 black button head
- 2x M8 black flat washer
- 2x M8 nylon washer
- 2x M8 flat washer
- 2x M8 flange nut
- 2x M6x16 black button head bolts
- 2x M6 black flat washer
- 2x M6 flange nut



<p>146. If required, fit the winch fairlead to the mesh fairlead mount using M10 or 3/8" fasteners supplied with the winch. This bar is only compatible with hawse type fairleads.</p>	<p><b>TOOLS REQUIRED</b></p> <p>Refer to instructions supplied by winch</p>
	<p><b>FASTENERS</b></p> <p>Supplied with winch</p>

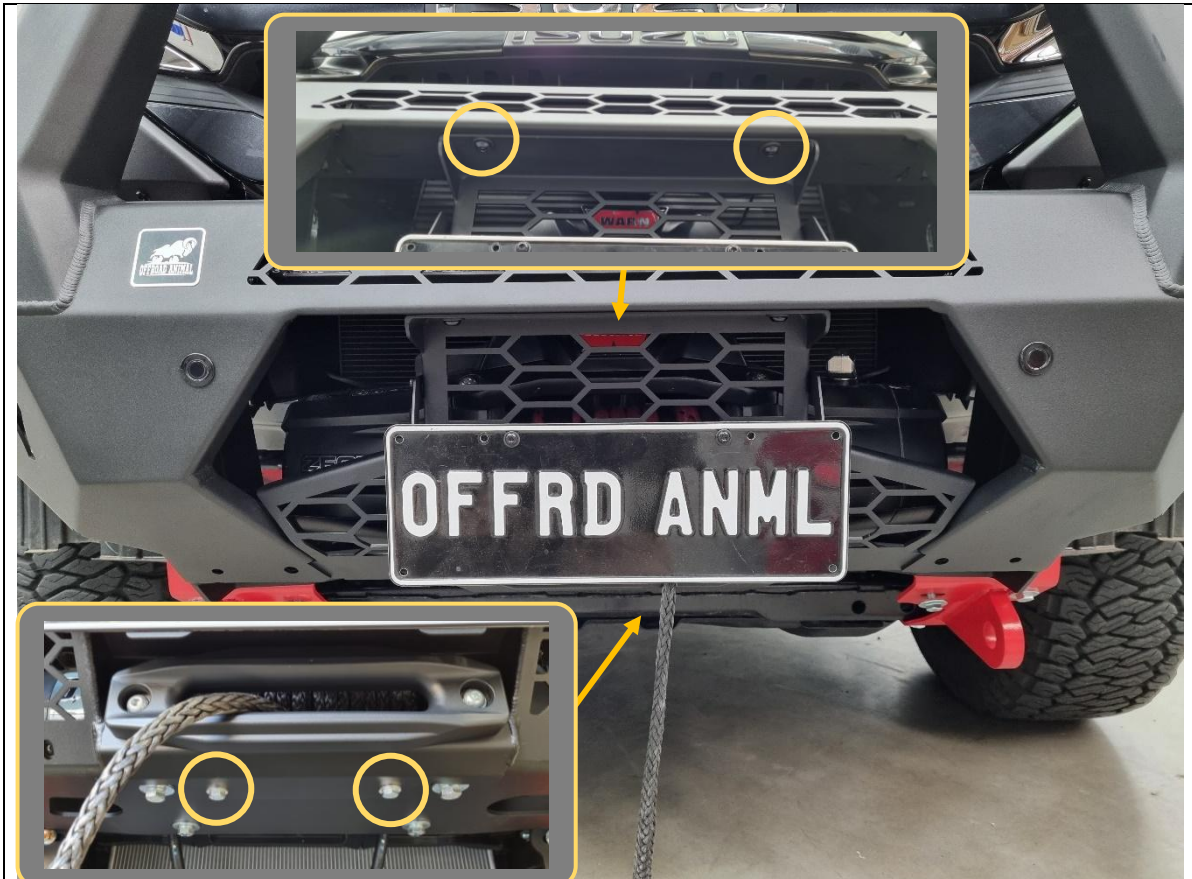

147. Fit the mesh fairlead mount to the centre of the bar, using 2x M8x16 black button head bolts + black washers (top), 2x M8x20 hex head bolts + heavy duty washers (bottom).

148. Tighten fasteners using 13mm socket/spanner and 5mm hex/Allen key.

149. Feed winch cable through the hawse fairlead if applicable.

**TOOLS REQUIRED**

13mm socket/spanner  
5mm hex/Allen key

**FASTENERS**

2x M8x16 black button head  
2x M8 black flat washer

2x M8x20 hex head  
2x M8 heavy duty washer



150. Prepare the U-0113 Blade lower bash plate for fitment.

151. First place 2x M10x50x1.25 fine pitch hex bolts through the rear two mounting holes, then stack 1x P-0306 and P-0394 spacer block on each, as shown (the stacking order doesn't matter).

**TOOLS REQUIRED**

**FASTENERS**

- 2x M10x50x1.25 hex bolt
- 2x P-0306 spacer block
- 2x P-0394 space block



- 152. Fit the Blade lower bash plate to the vehicle.
- 153. Loosely secure to the chassis at the rear with the pre-fitted M10x50x1.25 hex bolts.

**TOOLS REQUIRED**

**FASTENERS**



- 154. Temporarily remove the 2x M10x30 hex bolts from the impact assemblies in preparation for fitting the main centre bash plate. Set them aside.
- 155. Fit the centre bash plate and secure the top to the bullbar using 4x M8x20 black button head bolts and black washers.

**TOOLS REQUIRED**

5mm hex/Allen key  
16/17mm socket/spanner

**FASTENERS**

4x M8x20 black button head bolt  
4x M8 black flat washer

2x M10x30 hex bolt  
2x M10 heavy duty washer  
2x M10 flange nut

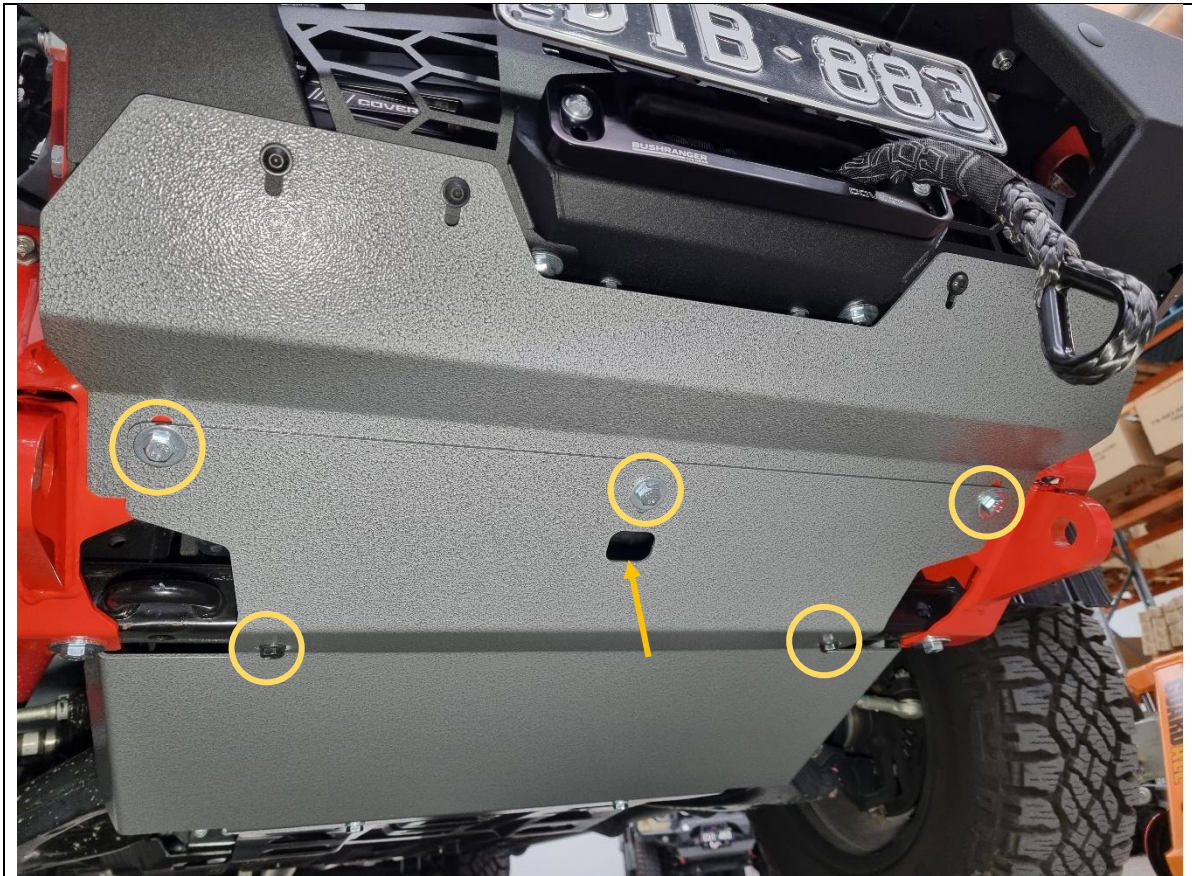

<p>156. Fit the supplementary bash plate and secure the rear through the Blade lower bash plate and into the chassis using the 2x factory 14mm hex bolts removed earlier.</p> <p>157. Secure the front of the supplementary bash plate to the centre bash plate/impact assemblies/tow points with 3x M10x30 hex bolts, heavy duty washers and flange nuts.</p>	<p><b>TOOLS REQUIRED</b></p> <p>14mm socket/spanner 16mm socket/spanner</p>
<p>Reach through the small access hole in the supplementary bash plate (see arrow) to reach middle flange nut.</p>	<p><b>FASTENERS</b></p> <p>2x factory 14mm hex bolt 3x M10x30 hex bolt 3x M10 heavy duty washer 3x M10 flange nut</p>

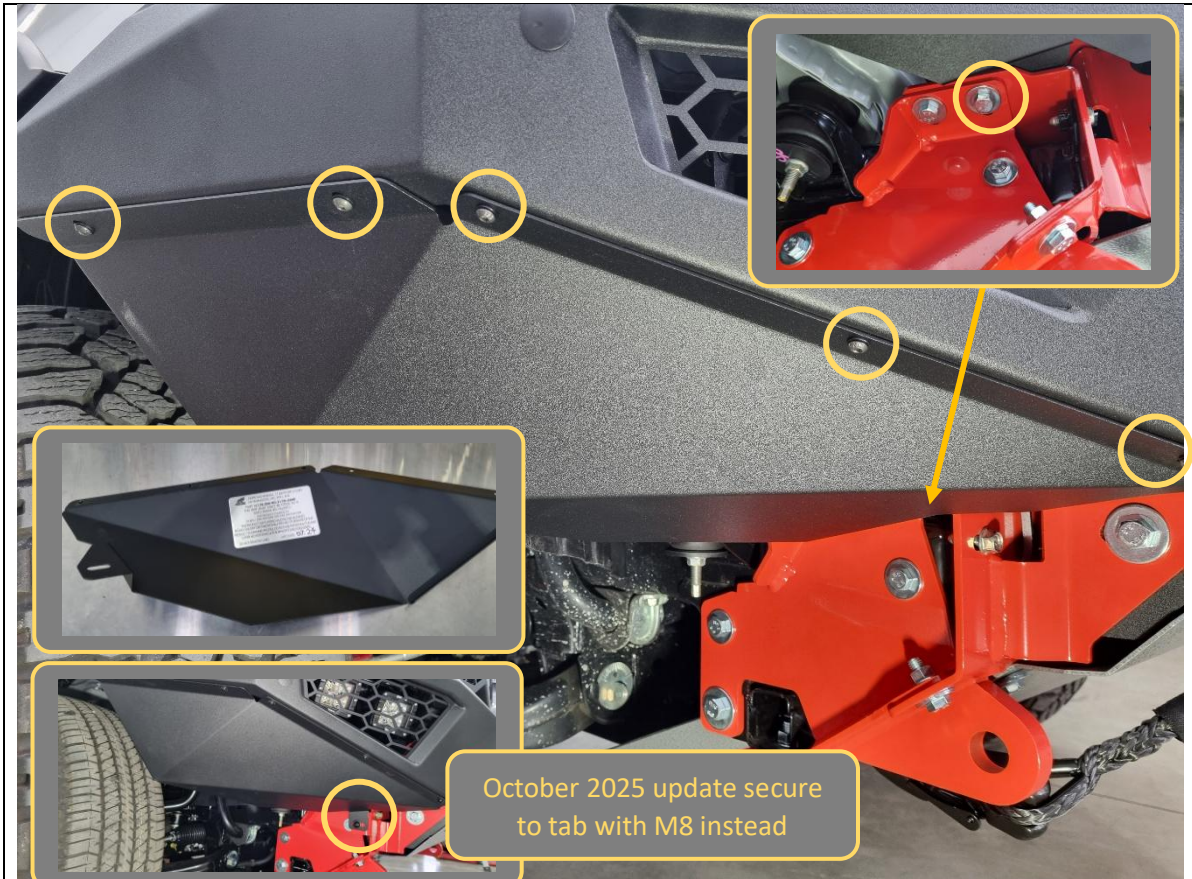

<p>158. Temporarily remove the 2x M10x30 hex bolts from the impact assemblies in preparation for fitting the bash plate. Set them aside.</p> <p><b>OCTOBER 2025 UPDATE</b> New mount with extra tab (refer to photo on Page 43) does not require M10 bolt to be removed.</p>	<p><b>TOOLS REQUIRED</b></p>
<p>159. Affix the supplied ADR compliance plate on the inside of one of the side underpanels.</p> <p>160. Fit the side underpanels by first sitting the bottom mount on top of the impact assembly, then loosely secure to the M6 cage nuts in the bullbar with 5x M6x16 black button head bolts and black washers, each.</p> <p>161. Loosely secure the bottom of side underpanels to the impact assemblies using the M10x30 hex bolts removed earlier.</p> <p><b>OCTOBER 2025 UPDATE</b> Loosely secure the bottom of side underpanel to the impact assembly using 1x M8x20 black button head bolt, black washer and flange nut.</p>	<p><b>FASTENERS</b></p> <p>10x M6x16 black button head bolt 10x M6 black flat washer</p> <p>2x M10x30 hex bolt 2x M10 heavy duty washer 2x M10 flange nut</p> <p><b>October 2025 update</b> 2x M8x20 black button head 2x M8 black flat washer 2x M8 flange nut</p>

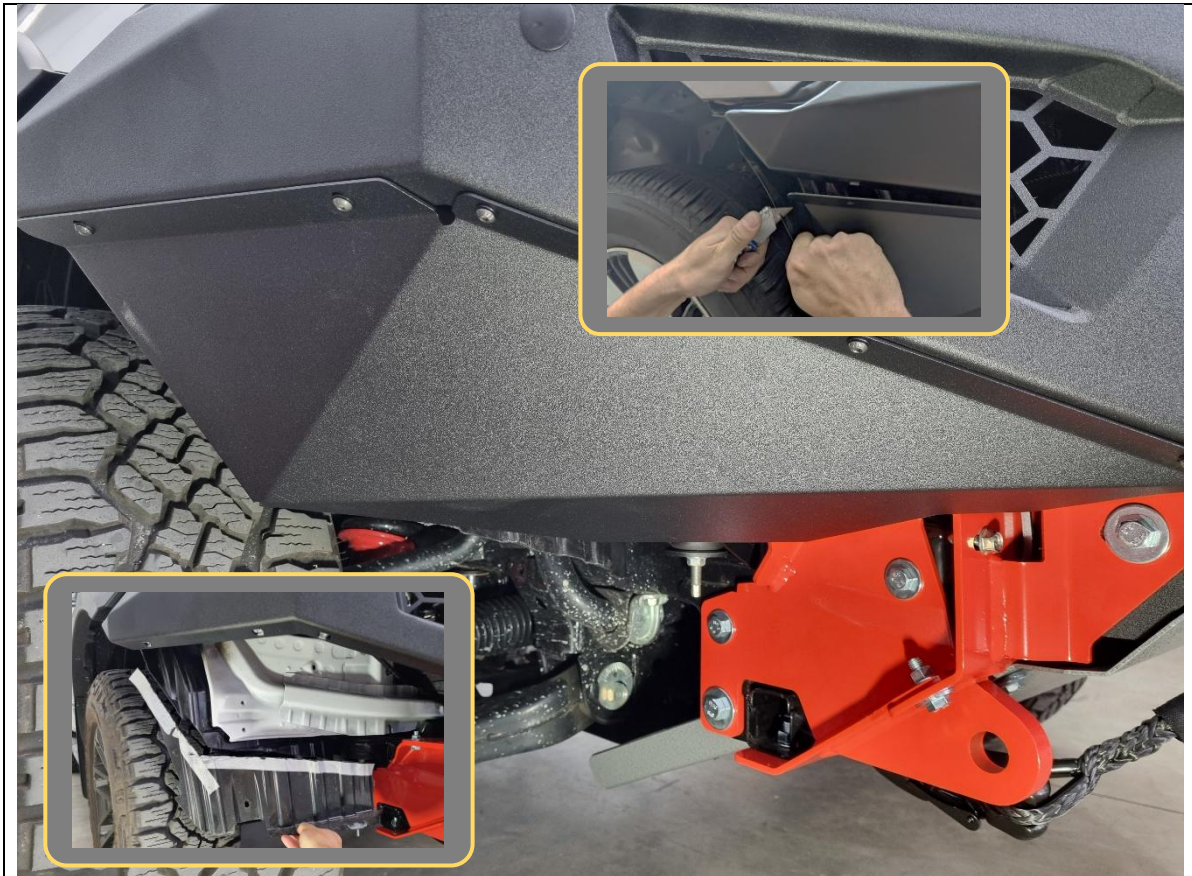

- 162. Using a sharp utility knife, cut back the plastic inner wheel arch liner to match the profile of the side underpanel.
- 163. Tuck the wheel arch liner behind the flange of the side underpanel.
- 164. Tighten all side underpanel bolts and repeat for other side.

**TOOLS REQUIRED**

Utility knife

4mm hex/Allen key  
5mm hex/Allen key  
16mm socket

**FASTENERS**

<p>165. <b>Optional.</b> Drill a hole through the inner wheel arch liner and use a cable tie to secure it to the body, as shown.</p>	<p><b>TOOLS REQUIRED</b></p> <p>Electric drill Cable tie</p>
	<p><b>FASTENERS</b></p>



<p>166. Review fitment and double check all bolts are tightened correctly.</p> <p>167. Check all wiring is connected, and that fog lights and indicators (Toro only) are all functional.</p> <p><b>Congratulations! You're done!</b></p> <p><b>Head for the tracks in your newly protected Blade!</b></p>	<p><b>TOOLS REQUIRED</b></p>
	<p><b>FASTENERS</b></p>